

# *Micro HiFi Component System*

---

## Operating Instructions

## Owner's Record

The model and serial numbers are located on the rear panel of the unit. Record the serial number in the space provided below. Refer to them whenever you call upon your Sony dealer regarding this product.

Model No. CMT-CP33MD      Serial No. \_\_\_\_\_



## *CMT-CP33MD*

# WARNING

**To prevent fire or shock hazard, do not expose the unit to rain or moisture.**  
To avoid electrical shock, do not open the cabinet. Refer servicing to qualified personnel only.

Do not install the appliance in a confined space, such as a bookcase or built-in cabinet.



This appliance is classified as a CLASS 1 LASER product. The CLASS 1 LASER PRODUCT MARKING is located on the rear exterior.



The following caution label is located inside the unit.



IN NO EVENT SHALL SELLER BE LIABLE FOR ANY DIRECT, INCIDENTAL OR CONSEQUENTIAL DAMAGES OF ANY NATURE, OR LOSSES OR EXPENSES RESULTING FROM ANY DEFECTIVE PRODUCT OR THE USE OF ANY PRODUCT.

## NOTICE FOR THE CUSTOMERS IN THE U.S.A.

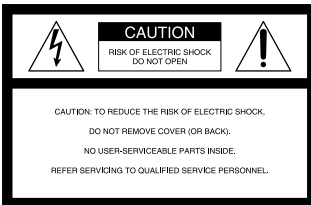

This symbol is intended to alert the user to the presence of uninsulated "dangerous voltage" within the product's enclosure that may be of sufficient magnitude to constitute a risk of electric shock to persons.



This symbol is intended to alert the user to the presence of important operating and maintenance (servicing) instructions in the literature accompanying the appliance.

## CAUTION

The use of optical instruments with this product will increase eye hazard.

## INFORMATION

This equipment has been tested and found to comply with the limits for a Class B digital device, pursuant to Part 15 of the FCC Rules. These limits are designed to provide reasonable protection against harmful interference in a residential installation. This equipment generates, uses, and can radiate radio frequency energy and, if not installed and used in accordance with the instructions, may cause harmful

interference to radio communications. However, there is no guarantee that interference will not occur in a particular installation. If this equipment does cause harmful interference to radio or television reception, which can be determined by turning the equipment off and on, the user is encouraged to try to correct the interference by one or more of the following measures:

- Reorient or relocate the receiving antenna.
- Increase the separation between the equipment and receiver.
- Connect the equipment into an outlet on a circuit different from that to which the receiver is connected.
- Consult the dealer or an experienced radio/TV technician for help.

## CAUTION

You are cautioned that any changes or modifications not expressly approved in this manual could void your authority to operate this equipment.

## NOTICE FOR THE CUSTOMERS IN CANADA

## CAUTION

TO PREVENT ELECTRIC SHOCK, DO NOT USE THIS POLARIZED AC PLUG WITH AN EXTENSION CORD, RECEPTACLE OR OTHER OUTLET UNLESS THE BLADES CAN BE FULLY INSERTED TO PREVENT BLADE EXPOSURE.

This system is equipped with the Dolby® B-type noise reduction system.

\* Dolby noise reduction manufactured under license from Dolby Laboratories Licensing Corporation. "DOLBY" and the double-D symbol  are trademarks of Dolby Laboratories Licensing Corporation.

---

# Table of Contents

---

## Getting Started

Step 1: Hooking up the system .....	4
Step 2: Setting the time .....	6
Step 3: Presetting radio stations .....	7

---

## Basic Operations

Playing a CD .....	9
Recording a CD on an MD or a tape .....	10
Playing an MD .....	14
Playing a tape .....	15
Recording a tape on an MD	
— TAPE-MD Synchro Recording ...	16
Listening to the radio — Preset Tuning ..	18
Recording from the radio	
— Manual Recording .....	19

---

## The CD Player

Playing CD tracks repeatedly	
— Repeat Play .....	22
Playing CD tracks in random order	
— Shuffle Play .....	23
Programing CD tracks — Program Play ..	23
Using the CD display .....	25
Labeling a CD — Disc Memo .....	26

---

## The MD Deck — Play

Playing MD tracks repeatedly	
— Repeat Play .....	28
Playing MD tracks in random order	
— Shuffle Play .....	28
Programing MD tracks	
— Program Play .....	29
Using the MD display .....	30

---

## The MD Deck — Recording

Before you start recording .....	31
Recording your favorite CD tracks on an MD	
— CD-MD Synchro Recording .....	32
Recording on an MD manually	
— Manual Recording .....	34
Starting recording with 6 seconds of prestored audio data	
— Time Machine Recording .....	35
Marking track numbers .....	37

Making a space between tracks 3 seconds long — Smart Space .....	39
Adjusting the recording level .....	41
Monaural recording .....	42

---

## The MD Deck — Editing

Before you start editing .....	44
Labeling an MD — Name Function .....	45
Erasing recordings — Erase Function ...	47
Moving recorded tracks	
— Move Function .....	51
Dividing recorded tracks	
— Divide Function .....	52
Combining recorded tracks	
— Combine Function .....	53
Undoing the last edit — Undo Function ..	55

---

## The Tape Deck — Recording

Recording your favorite CD tracks on a tape	
— CD-TAPE Synchro Recording ....	56
Recording an MD on a tape .....	59
Recording on a tape manually	
— Manual Recording .....	61

---

## Other Features

Adjusting the sound .....	62
Labeling the preset stations	
— Station Name .....	63
Using the Radio Data System (RDS)* ....	65
Falling asleep to music — Sleep Timer ..	65
Waking up to music — Daily Timer .....	66
Timer recording radio programs .....	68

---

## Connecting optional components

Connecting optional A/V components ....	69
Connecting external antennas .....	70

---

## Additional Information

Precautions .....	71
System limitations of MDs .....	73
Troubleshooting .....	74
Self-diagnosis display .....	78
Specifications .....	81
Parts descriptions for the remote .....	83
List of program types (PTY) .....	85
Index .....	86

\* European model only

## Step 1: Hooking up the system

Perform the following procedure **1** to **4** to hook up your system using the supplied cords and accessories.

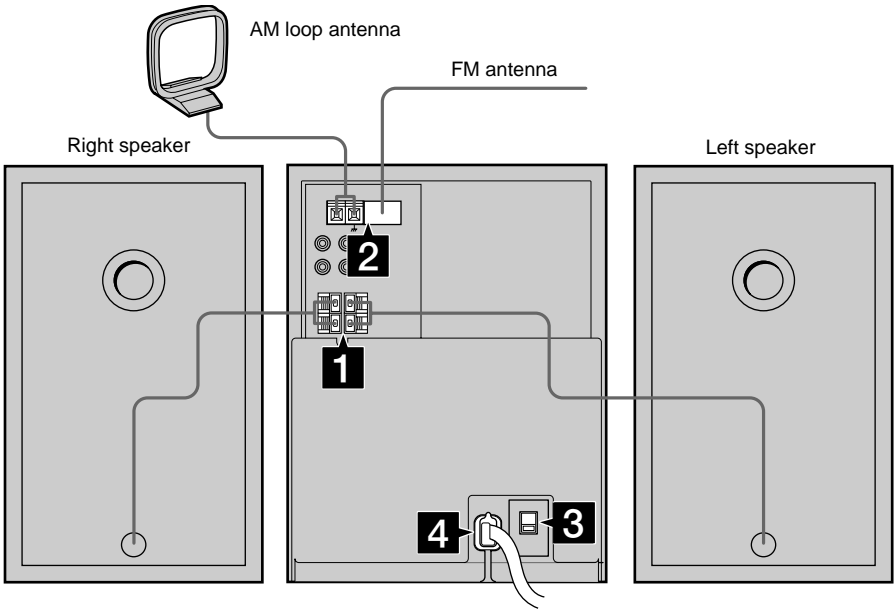

### **1** Connect the speakers.

Connect the speaker cords to the SPEAKER terminals as shown below.

Keep the speaker cords away from the antennas to prevent noise.

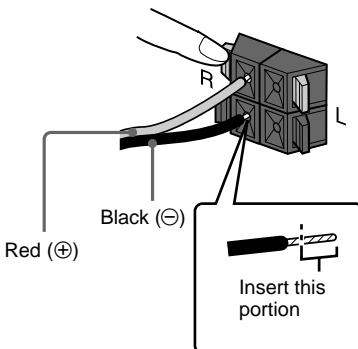

### **2** Connect the FM/AM antennas.

Set up the AM loop antenna, then connect it.

**Jack type A**

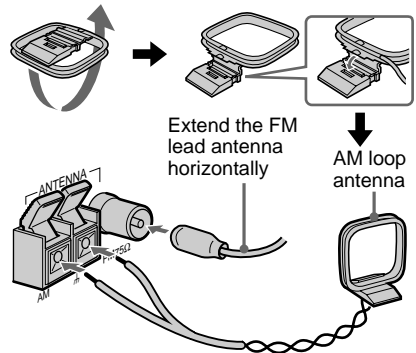

Inserting two size AA (R6) batteries into the remote

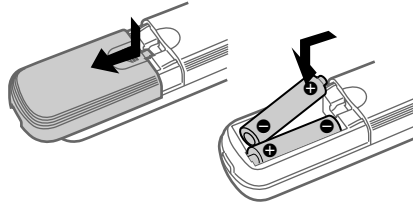

#### Tip

With normal use, the batteries should last for about six months. When the remote no longer operates the system, replace both batteries with new ones.

#### Notes

- If you do not use the remote for a long period of time, remove the batteries to avoid possible damage from battery leakage.
- Be sure to insert the batteries in correct direction.
- Do not mix new batteries with old ones.
- Do not use different types of batteries together.
- Do not use a battery that is leaking.
- If the battery leaks, clean the battery compartment and replace all the batteries with new ones.

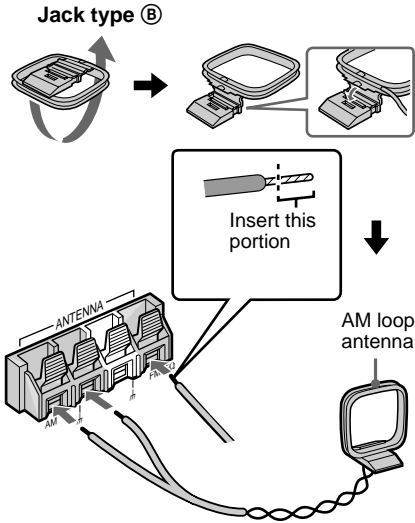

- 3** For models with a voltage selector, set **VOLTAGE SELECTOR** to the local power line voltage.

110V – 120V



220V – 240V  
VOLTAGE  
SELECTOR

- 4** Connect the power cord to a wall outlet.  
If the plug does not fit the wall socket, detach the supplied plug adaptor (only for models equipped with an adaptor).

## Step 2: Setting the time

You must set the time beforehand to use the timer functions.

The clock is on a 24-hour system for the European model, and a 12-hour system for other models.

The 24-hour system is used for illustration purposes.

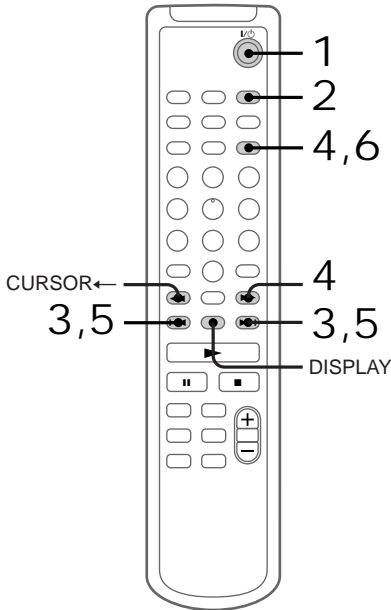

1 Turn on the system.

2 Press CLOCK/TIMER SET.

The clock appears and the hour indication flashes.



3 Press ◀◀ or ▶▶ to set the hour.

4 Press ENTER/YES or CURSOR→.  
The minute indication flashes.

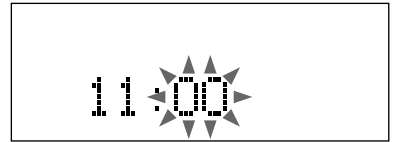

5 Press ◀◀ or ▶▶ to set the minute.

6 Press ENTER/YES.  
The clock starts.

If you made a mistake

Press CURSOR← or → repeatedly until the incorrect item flashes, then set it again.

To change the preset time

You can change the preset time while the system is off.

1 Press DISPLAY to display the clock.

2 Press CLOCK/TIMER SET.

3 Repeat steps 3 to 6 of "Setting the time."

Tip

The upper dot of the colon flashes for the first 30 seconds, and the lower dot flashes for the last 30 seconds of each minute.

## Step 3: Presetting radio stations

You can preset up to 30 stations, 20 for FM and 10 for AM.

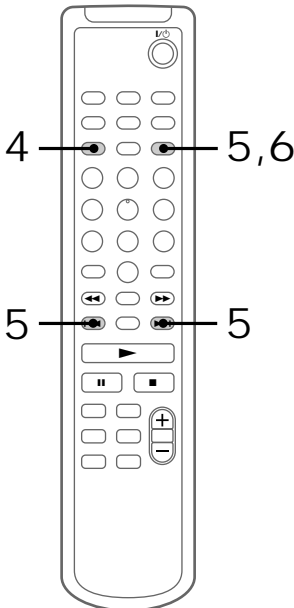
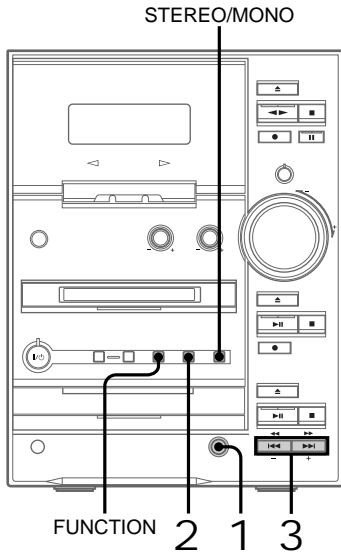

- 1 Press TUNER/BAND to select “FM” or “AM.”

Pressing TUNER/BAND turns on the system.

- 2 Press TUNING MODE repeatedly until “AUTO” appears.

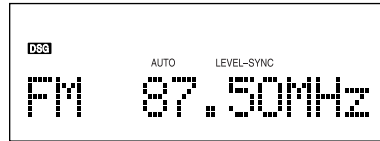

- 3 Press TUNING + or –.

The frequency indication changes and the scanning stops when the system tunes in a station. “TUNED” and “STEREO” (for a stereo program) appear.

- 4 Press MENU/NO on the remote.

- 5 Press **◀◀** or **▶▶** on the remote repeatedly until “P.Memory ?” appears, then press ENTER/YES on the remote. A preset number appears in the display. The stations are stored from preset number 1.

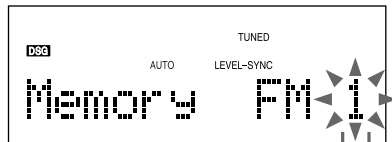

Preset number

- 6 Press ENTER/YES.

“Complete !!” appears, and then the station is stored.

- 7 Repeat steps 1 to 6 to preset other stations.

*continued*

### Step 3: Presetting radio stations (continued)

To stop scanning

Press TUNING MODE.

To tune in a station with a weak signal

Press TUNING MODE repeatedly until "AUTO" and "PRESET" disappear from the display in step 2, then press TUNING + or – repeatedly to tune in the station manually.

To set another station to the exist preset number

Start over from step 1. After step 5, press ◀◀ or ▶▶ on the remote to select the preset number on which you want to store the station.

To erase a preset station

- 1 Press MENU/NO on the remote.
- 2 Press ◀◀ or ▶▶ repeatedly until "P.Erase ?" appears.  
Select "P.All Erase" when you want to erase all the preset stations.
- 3 Press ENTER/YES on the remote.
- 4 Press ◀◀ or ▶▶ repeatedly to select the preset number you want to erase.
- 5 Press ENTER/YES.  
"Complete !!" appears.

When you erase a preset number, the preset number decreases by one and all preset numbers following the erased one are renumbered.

To change the AM tuning interval (except for the European model)

The AM tuning interval is factory-set to 9 kHz (10 kHz in some areas). To change the AM tuning interval, tune in any AM station first, then turn off the system. While holding down the TAPE ■ button, turn the system back on. When you change the interval, all the AM preset stations are erased. To reset the interval, repeat the same procedure.

Tips

- The preset stations are retained for about a day even if you disconnect the power cord or if a power failure occurs.
- You can label the preset stations (see page 63).
- When an FM stereo program has static noise, press STEREO/MONO until "MONO" scrolls in the display. There will be no stereo effect, but the reception will improve. Press the button again to restore the stereo effect.



# Playing a CD

To turn on the system, press I/O (power).

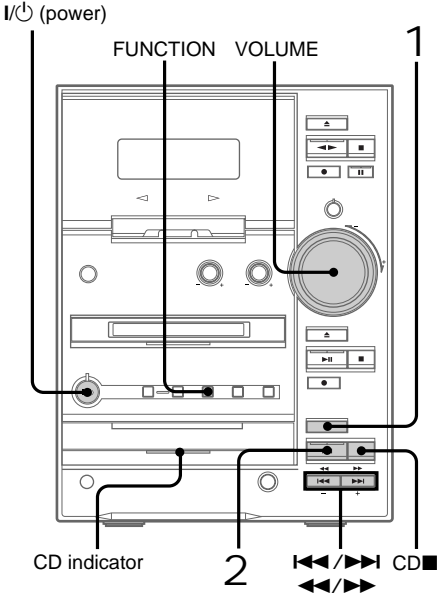

## 2 Press CD ►||

The disc tray closes and play starts.

The indicator on the CD ►|| button lights green.

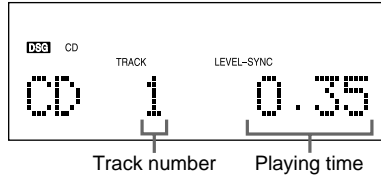

To	Do this
Stop play	Press CD ■.
Pause	Press CD ►  . The indicator on the CD ►   button lights orange. Press again to resume play.
Select a track	Press ◀◀ or ▶▶ repeatedly.
Find a point in a track	Press and hold ◀◀ or ▶▶ during play and release it at the desired point. "—OVER—" appears at the end of the CD.
Remove the CD	Press CD ▲.
Adjust the volume	Turn VOLUME.

## 1 Press CD ▲ and place a CD on the disc tray.

With the label side up. When you play a CD single (8 cm CD), place it on the inner circle of the tray.

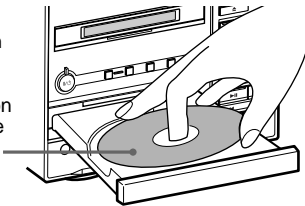

To close the disc tray, press CD ▲ again.

*continued*

## Playing a CD (continued)

### Tips

- If you turn on the system when there is a CD on the disc tray, the CD indicator lights orange.
- If there is no CD in the player, “CD No Disc” appears in the display.
- Pressing CD ►|| when the system is off automatically turns on the system and starts CD play if there is a CD on the disc tray (**One Touch Play**).
- You can switch from another source to the CD player and start playing a CD just by pressing CD ►|| (**Automatic Source Selection**).
- You can start playing from the desired track in step 2.
  - 1 Press ◀◀ or ▶▶ repeatedly until the desired track appears.
  - 2 Press CD ►||.

Or, press the number buttons on the remote.

The playback automatically starts. To enter track numbers 10 or over, press >10 and the track number. To enter 0, use the 10/0 button.

### Notes

- Do not use a CD with tape, seals or paste on it as this may damage the CD player.
- Do not push the disc tray to close it, as this may damage the CD player. Press CD ▲ to close the disc tray.
- If you press CD ▲ to open or close the disc tray while listening to another sound source, the CD indicator lights orange even if there is no CD in the tray. To turn off the CD indicator, press FUNCTION repeatedly to switch the function to CD.

## Recording a CD on an MD or a tape

You can make a digital recording of a CD on an MD or an analog recording on a tape. You can also record a program of favorite tracks (see pages 32 and 56).

To turn on the system, press I/⏻(power).

### Recording on an MD

If you use a partially recorded MD, recording starts after the recorded tracks. To erase the recorded contents, see “Erasing recordings” on page 47.

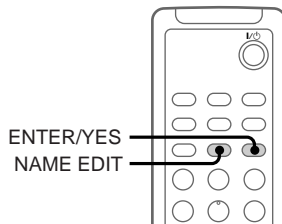
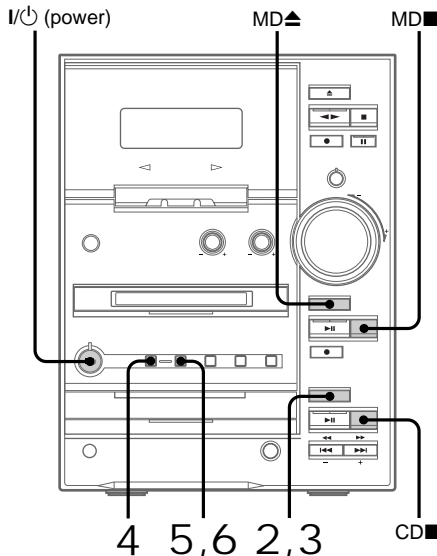

**1** Insert a recordable MD.

With the label side up, and the shutter on the righthand side

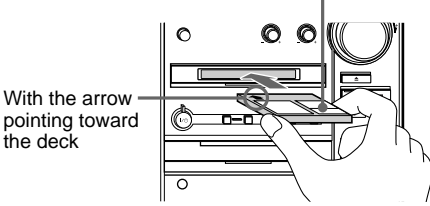

**2** Press CD and place a CD on the disc tray.

With the label side up. When you play a CD single (8 cm CD), place it on the inner circle of the tray.

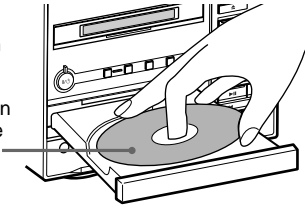

**3** Press CD to close the disc tray.

**4** Press SYNCHRO REC repeatedly until "CD-MD SYNC" appears.

**5** Press ENTER/START.

The MD deck stands by for recording and the CD player pauses for play.

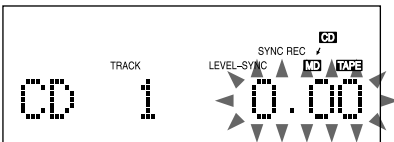

**6** Press ENTER/START again.

Recording starts.

When the recording is completed, the CD player and the MD deck stop automatically.

To stop recording

Press CD or MD

Tips

- The track numbers of the CD are recorded on to the MD automatically.
- Depending on the disc, CD TEXT information may also be recorded (except when you record on an MD and a tape at the same time). If "CD-TEXT" flashes during recording, press NAME EDIT on the remote, and then press ENTER/YES on the remote to record the title of the current track. (If "CD-TEXT" is lit, it is automatically recorded.)

Note

If "Cannot SYNC" appears, a disc is not loaded or you cannot record on that MD (see page 79).

If the MD becomes full during recording

The CD player and the MD deck stop automatically.

Before pulling out the power cord

MD recording is completed when the MD Table of Contents (TOC) is updated. The TOC is updated when you eject the MD or press I/O to turn off the system. Do not pull out the power cord before updating the TOC (while "TOC" is lit) or while updating the TOC (while "TOC" or "STANDBY" is flashing) to ensure a complete recording.

*continued*

Recording a CD on an MD or a tape (continued)

**Recording on a tape**

You can use TYPE I (normal) or TYPE II (CrO<sub>2</sub>) tape. The recording level is automatically adjusted.

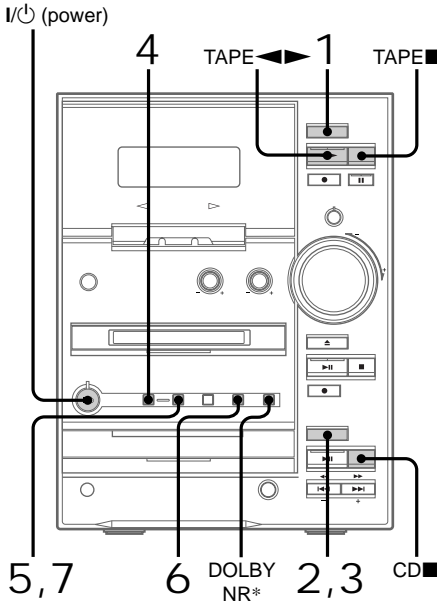

\* This tape deck is equipped with the Dolby B-type noise reduction system.

1 Press TAPE ▲ and insert a blank tape.

With the side you want to record on facing you

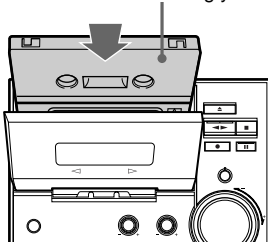

2 Press CD ▲ and place a CD on the disc tray.

With the label side up. When you play a CD single (8 cm CD), place it on the inner circle of the tray.

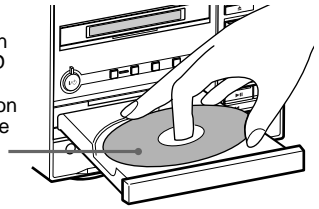

3 Press CD ▲ to close the disc tray.

4 Press SYNCHRO REC repeatedly until "CD-TAPE SYNC" appears.

5 Press ENTER/START. The tape deck stands by for recording and the CD player pauses for play.

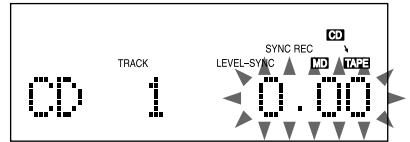

6 Press DIRECTION repeatedly until ⇌ appears to record on one side or ⇔ (or ⇔) to record on both sides.

7 Press ENTER/START. Recording starts. When the recording is completed, the CD player and the tape deck stop automatically.

To stop recording  
Press CD ■ or TAPE ■

### Tips

- When you want to record on the reverse side, press TAPE ◀▶ to light up the left indicator in step 6.
- When you record on both sides, be sure to start from the front side. If you start from the reverse side, recording stops at the end of the reverse side.
- If you select both sides recording and the tape reaches the end of the front side part-way through a track, the entire track is recorded again from the beginning of the reverse side.
- When you want to reduce the hiss noise in low-level, high-frequency signals, press DOLBY NR after step 5 so “NR” appears in the display.

### Note

If “Cannot SYNC” appears, a disc or a tape is not loaded or you cannot record on that tape (see page 80).

### Tips

- Even if the MD or the tape ends part-way through the recording, the other continues recording.
- If you select both sides recording and the tape reaches the end of the front side part-way through a track, the entire track is recorded again from the beginning of the reverse side. In this case, the entire track may also be recorded again on the MD.

### Note

If “Cannot SYNC” appears, a disc or a tape is not loaded or you cannot record on that tape (see pages 79 and 80).

## Recording on an MD and a tape at the same time

- 1 Perform step 1 of “Recording on an MD” (see page 10) and steps 1 to 3 of “Recording on a tape” (see page 12).
- 2 Press SYNCHRO REC repeatedly until “DUAL SYNC” appears.
- 3 Perform steps 5 to 7 of “Recording on a tape.”

### To stop recording

Press CD ■ MD ■ or TAPE ■

# Playing an MD

To turn on the system, press I/⏻ (power). You can play an MD just like a CD.

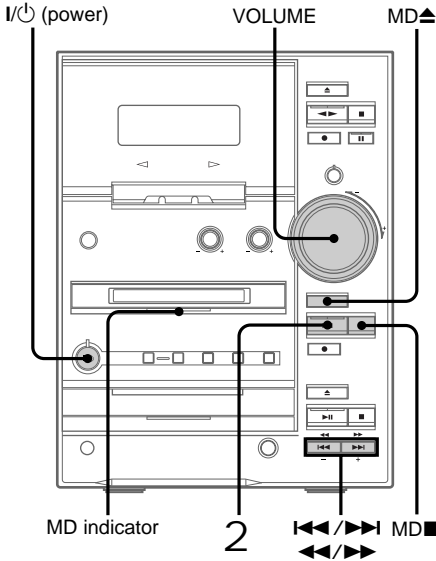

## 1 Insert an MD.

With the label side up, and the shutter on the righthand side

With the arrow pointing toward the deck

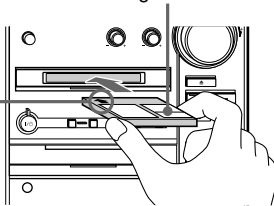

## 2 Press MD ►||

Play starts.

The indicator on the MD ►|| button lights green.

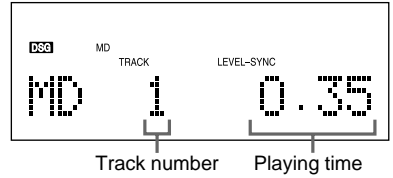

To	Do this
Stop play	Press MD ■.
Pause	Press MD ►  . The indicator on the MD ►   button lights orange. Press again to resume play.
Select a track	Press ◀◀ or ▶▶ repeatedly.
Find a point in a track	Press and hold ◀◀ or ▶▶ during play and release it at the desired point.
Remove the MD	Press MD ▲.
Adjust the volume	Turn VOLUME.

## Before inserting an MD

When the system is on, make sure the MD indicator is off. If the MD indicator is lit orange, another MD is already inserted. Press MD ▲ and remove the MD.

## Tips

- Pressing MD ►|| when the system is off automatically turns on the system and starts MD play if there is an MD in the system (**One Touch Play**).
- You can switch from another source to the MD deck and start playing an MD just by pressing MD ►|| (**Automatic Source Selection**).
- You can start playing from the desired track in step 2.
  - 1 Press ◀◀ or ▶▶ repeatedly until the desired track appears.
  - 2 Press MD ►||.

Or, press the number buttons on the remote.

The playback automatically starts. To enter track numbers 10 or over, press >10 (press twice to enter 100 or over) and the track number. To enter 0, use the 10/0 button.

## Note

Do not use an MD on which the label sticks out from the edge or on which the label is not positioned correctly. Such labels can cause the MD deck to malfunction.

## Playing a tape

You can use any type of tape, TYPE I (normal), TYPE II (CrO<sub>2</sub>) or TYPE IV (metal), since the tape deck automatically detects the tape type (ATS\*).

To turn on the system, press I/⏻(power).

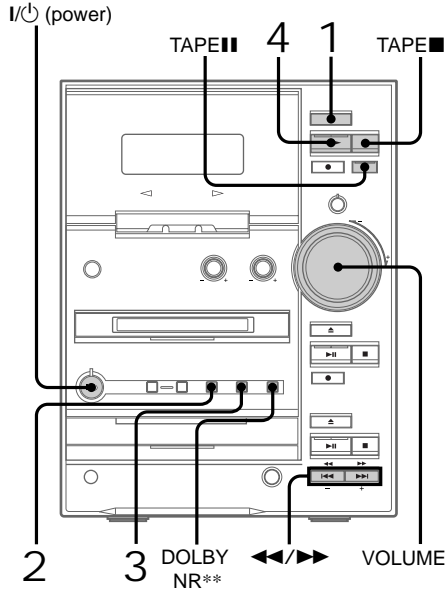

\* ATS: Automatic Tape Selection

\*\* This tape deck is equipped with the Dolby B-type noise reduction system.

- 1 Press TAPE ▲ and insert a recorded tape.

With the side you want to play facing you

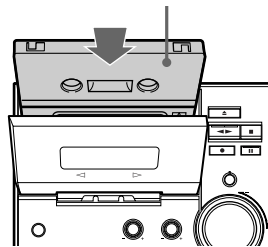

*continued*

## Playing a tape (continued)

2 Press **FUNCTION** repeatedly to switch the function to **TAPE**.

3 Press **DIRECTION** repeatedly until  $\rightleftarrows$  appears to play one side or  $\rightleftarrows$  (or  $\rightleftarrows$ \*) to play both sides.

\* The tape deck stops automatically after repeating the sequence five times.

4 Press **TAPE**  $\blacktriangleleft\blacktriangleright$ .

The right indicator on the **TAPE**  $\blacktriangleleft\blacktriangleright$  button lights up, then the tape starts playing from the front side.

To change the playback direction, press **TAPE**  $\blacktriangleleft\blacktriangleright$  again. The left indicator lights up, then the reverse side starts playing.

To	Do this
Stop play	Press <b>TAPE</b> ■.
Pause	Press <b>TAPE</b> ■■. The indicator on the <b>TAPE</b> ■■ button lights up. Press again to resume play.
Fast-forward or rewind	Press $\blacktriangleleft$ or $\blacktriangleright$ .
Remove or replace the tape	Press <b>TAPE</b> ▲.
Adjust the volume	Turn <b>VOLUME</b> .

### Tips

- Pressing **TAPE**  $\blacktriangleleft\blacktriangleright$  when the system is off automatically turns on the system and starts playing a tape if there is a tape in the system (**One Touch Play**).
- You can switch from another source to the tape deck and start playing a tape just by pressing **TAPE**  $\blacktriangleleft\blacktriangleright$  (**Automatic Source Selection**).
- To listen to a tape recorded with the Dolby noise reduction system, press **DOLBY NR** so “ $\square\square$ ” appears in the display.

## Recording a tape on an MD — TAPE-MD Synchro Recording

You can make an analog recording of a tape on an MD. You can use **TYPE I** (normal), **TYPE II** (CrO<sub>2</sub>) or **TYPE IV** (metal) tape.

To turn on the system, press **I/⏻** (power).

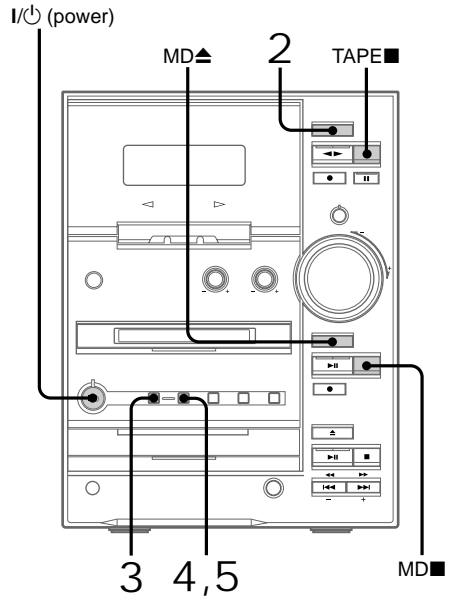

1 Insert a recordable MD.

With the label side up, and the shutter on the righthand side

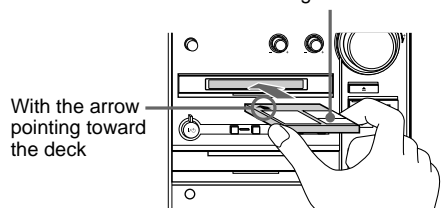



- 2 Press **TAPE**  and insert a tape.

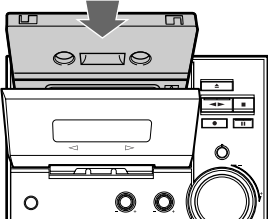

- 3 Press **SYNCHRO REC** repeatedly until “TAPE-MD SYNC” appears.

- 4 Press **ENTER/START**.

The MD deck stands by for recording and the tape deck pauses for play.

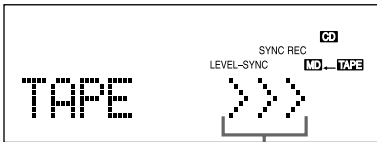

Tape playback side

>>> appears for the front side, and <<< for the reverse side. To play the side not indicated, press **TAPE**  and remove the tape to reverse the tape side, then perform steps 3 and 4 again.

- 5 Press **ENTER/START** again.

Recording starts.

When the recording is completed, the tape deck and the MD deck stop automatically.

### To stop recording

Press **TAPE**  or **MD** .

### Tips

- If you use a partially recorded MD, recording starts after the recorded tracks.
- If the Smart Space function is on and there is no sound input for about 3 seconds or more (but less than 30 seconds) while recording, the MD deck replaces this silence with a blank of about 3 seconds and continues recording. However, this function may not activate if there is noise.

### Note

If “Cannot SYNC” appears, a disc is not loaded or you cannot record on that MD (see page 79).

### If the MD becomes full during recording

The tape deck and the MD deck stop automatically.

### Before pulling out the power cord

MD recording is completed when the MD Table of Contents (TOC) is updated. The TOC is updated when you eject the MD or press **I/O** to turn off the system. Do not pull out the power cord before updating the TOC (while “TOC” is lit) or while updating the TOC (while “TOC” or “STANDBY” is flashing) to ensure a complete recording.

# Listening to the radio

## — Preset Tuning

Preset radio stations in the tuner's memory first (see page 7).

To turn on the system, press I/⏻(power).

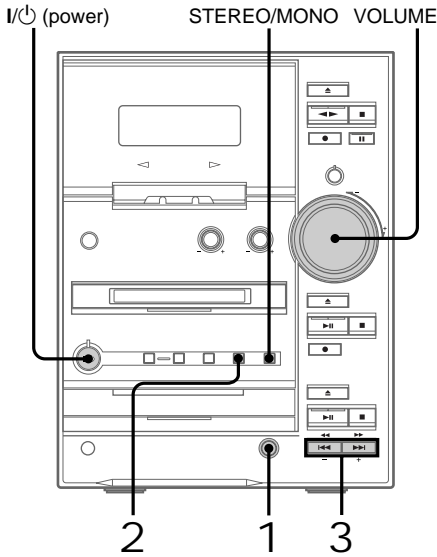

1 Press TUNER/BAND to select “FM” or “AM.”

2 Press TUNING MODE repeatedly until “PRESET” appears.

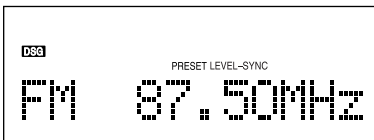

3 Press TUNING + or – to select the desired preset station.  
The preset number scrolls in the display, followed by the frequency.

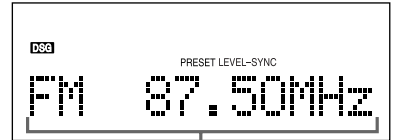

Frequency (or station name\* or RDS station name\*\*)

When you preset only one station, “ONE PRESET” appears in the display.

\* The station name appears only if you have labeled the station (see page 63).

\*\* European model only

To	Do this
Turn off the radio	Press I/⏻ to turn off the system.
Adjust the volume	Turn VOLUME.

To select the preset number using the number buttons on the remote

Press number buttons in step 3.

To enter preset numbers 10 or over, press >10 and the preset number. To enter 0, use the 10/0 button.

## Listening to non-preset radio stations

- Press TUNING MODE repeatedly until “AUTO” and “PRESET” disappear from the display in step 2, then press TUNING + or – to tune in the desired station (**Manual Tuning**).
- Press TUNING MODE repeatedly until “AUTO” appears in step 2, then press TUNING + or –. The frequency indication changes and the scanning stops when the system tunes in a station (**Automatic Tuning**).

### To cancel Automatic Tuning

Press TUNING MODE.

### Tips

- Pressing TUNER/BAND when the system is off automatically turns on the system and tunes in the last received station (**One Touch Play**).
- You can switch from another source to the tuner just by pressing TUNER/BAND (**Automatic Source Selection**).
- To improve broadcast reception, adjust the supplied antennas, or connect a commercially available external antenna (see page 70).
- When an FM stereo program has static noise, press STEREO/MONO until “MONO” scrolls in the display. There will be no stereo effect, but the reception will improve. Press the button again to restore the stereo effect.

## Recording from the radio — Manual Recording

You can make an analog recording of a radio program on an MD or a tape.

### Recording on an MD

If you use a partially recorded MD, recording starts after the recorded tracks. To erase the recorded contents, see “Erasing recordings” on page 47.

To turn on the system, press I/⏻(power).

I/⏻ (power)

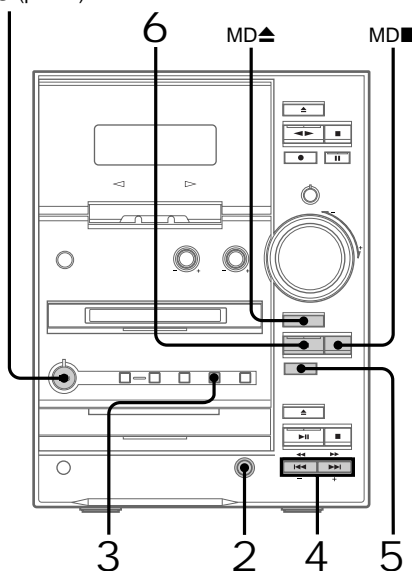

*continued*

## Recording from the radio (continued)

### 1 Insert a recordable MD.

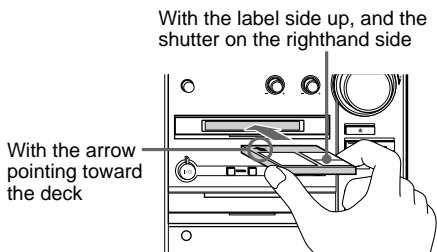

### 2 Press TUNER/BAND to select “FM” or “AM.”

### 3 Press TUNING MODE repeatedly until “PRESET” appears.

### 4 Press TUNING + or – to select the desired preset station.

The preset number scrolls in the display, followed by the frequency.

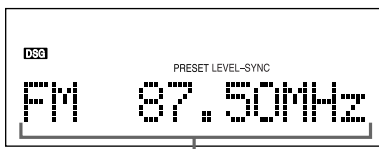

Frequency (or station name\* or RDS station name\*\*)

When you preset only one station, “ONE PRESET” appears in the display.

You can also select the preset numbers with the number buttons on the remote.

\* The station name appears only if you have labeled the station (see page 63).

\*\* European model only

### 5 Press MD REC ●

The MD deck stands by for recording and “REC” appears in the display.

### 6 Press MD ►||

Recording starts.

## To stop recording

Press MD ■

## Tips

- If noise is heard while recording an AM radio program, move the AM loop antenna to reduce the noise or connect a ground wire to the  $\hbar$  terminal (see page 71).
- You can record the MD in monaural format. For details, see “Monaural recording” on page 42.
- To record non-preset stations, press TUNING MODE repeatedly until “AUTO” and “PRESET” disappear from the display in step 3, then press TUNING + or – to tune in the desired station.

## Note

If the MD is record protected, “C11” and “Protected” appear alternately and the MD cannot be recorded. Remove the MD, then slide the record protection tab to the closed position (see page 32).

## Before pulling out the power cord

MD recording is completed when the MD Table of Contents (TOC) is updated. The TOC is updated when you eject the MD or press I/O to turn off the system. Do not pull out the power cord before updating the TOC (while “TOC” is lit) or while updating the TOC (while “TOC” or “STANDBY” is flashing) to ensure a complete recording.

## Recording on a tape

You can use TYPE I (normal) or TYPE II (CrO<sub>2</sub>) tape. The recording level is automatically adjusted.

To turn on the system, press I/⏻ (power).

I/⏻ (power)

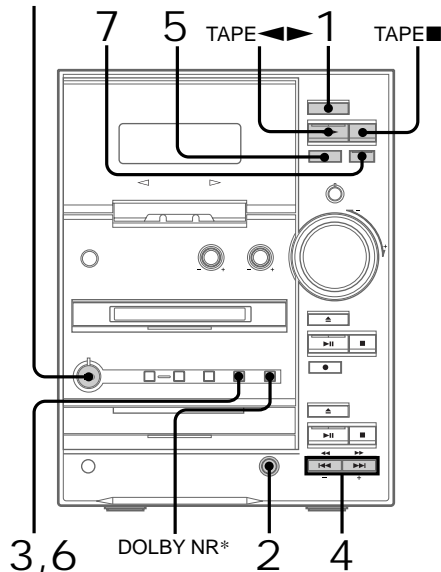

\* This tape deck is equipped with the Dolby B-type noise reduction system.

- 1 Press TAPE and insert a blank tape.

With the side you want to record on facing you

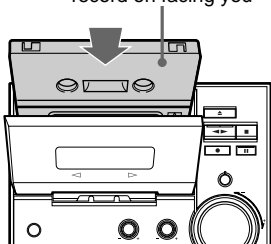

- 2 Press TUNER/BAND to select “FM” or “AM.”
- 3 Press TUNING MODE repeatedly until “PRESET” appears.
- 4 Press TUNING + or – to select the desired preset station.  
The preset number scrolls in the display, followed by the frequency.

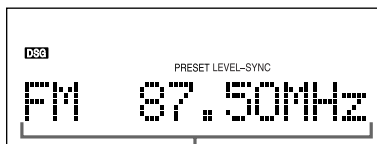

Frequency (or station name\* or RDS station name\*\*)

When you preset only one station, “ONE PRESET” appears in the display.

You can also select the preset numbers with the number buttons on the remote.

\* The station name appears only if you have labeled the station (see page 63).

\*\* European model only

- 5 Press TAPE REC .  
The tape deck stands by for recording and “REC” appears in the display.
- 6 Press DIRECTION repeatedly until appears to record on one side or (or ) to record on both sides.
- 7 Press TAPE .  
Recording starts.

*continued*

## Recording from the radio (continued)

To stop recording

Press **TAPE** ■

### Tips

- If noise is heard while recording an AM radio program, move the AM loop antenna to reduce the noise or connect a ground wire to the *h* terminal (see page 71).
- When you want to record on the reverse side, press **TAPE** ◀▶ to light up the left indicator in step 6.
- When you record on both sides, be sure to start from the front side. If you start from the reverse side, recording stops at the end of the reverse side.
- To record non-preset stations, press **TUNING MODE** repeatedly until “AUTO” and “PRESET” disappear from the display in step 3, then press **TUNING +** or **-** to tune in the desired station.
- When you want to reduce the hiss noise in low-level, high-frequency signals, press **DOLBY NR** after step 5 so “□□” appears in the display.

## Playing CD tracks repeatedly — Repeat Play

You can repeat a CD in normal play, Shuffle Play and Program Play.

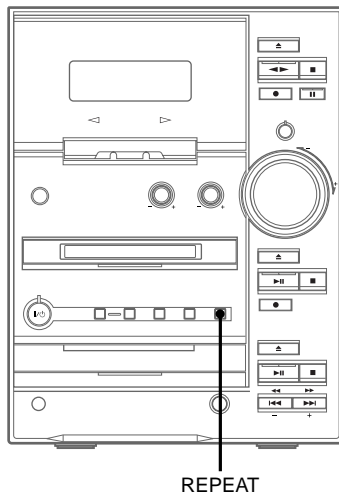

➔ Press **REPEAT** during play until “REPEAT” or “REPEAT 1” appears.

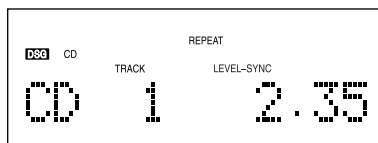

**REPEAT:** For all the tracks on the CD.

**REPEAT 1:** For a single track only.

### To cancel Repeat Play

Press **REPEAT** until “REPEAT” or “REPEAT 1” disappears.

## Playing CD tracks in random order — Shuffle Play

You can play all the tracks on a CD in random order.

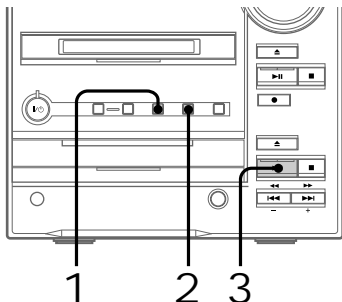

- 1 Press FUNCTION repeatedly to switch the function to CD.
- 2 Press PLAY MODE repeatedly until "SHUFFLE" appears.

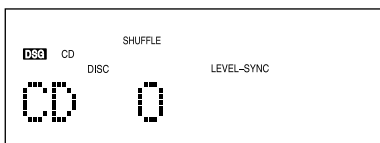

- 3 Press CD **▶||**. Shuffle Play starts.

### To cancel Shuffle Play

Press PLAY MODE repeatedly until "SHUFFLE" and "PGM" disappear.

### Tips

- You can start Shuffle Play during normal play by displaying "SHUFFLE."
- To skip a track, press **▶▶**.

## Programing CD tracks — Program Play

### — Program Play

You can make a program up to 25 tracks in the order you want them to be played. You can also make a Synchro Recording of the program on an MD or a tape (see pages 32 and 56).

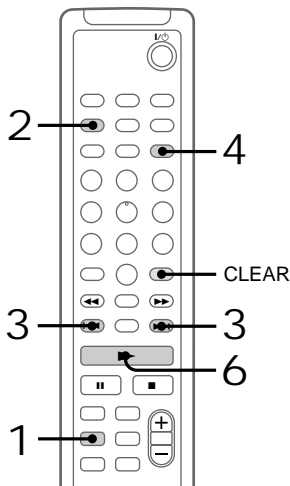

- 1 Press CD to switch the function to CD.
- 2 Press PLAY MODE repeatedly until "PGM" appears.
- 3 Press **◀◀** or **▶▶** repeatedly until the desired track number appears in the display.

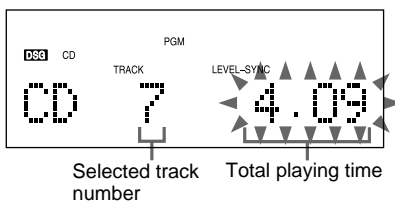

Selected track number

Total playing time

continued

## Programing CD tracks (continued)

### 4 Press ENTER/YES.

The track is programmed.

“Step” appears, followed by the number of the track in the programmed sequence. The number of the last programmed track appears, followed by the total playing time of the program. If you have made a mistake, you can clear the last programmed track from the program by pressing CLEAR.

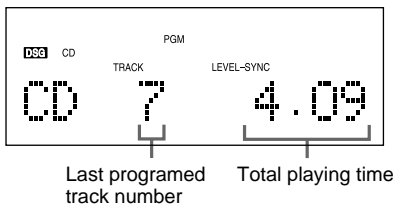

### 5 To program additional tracks, repeat steps 3 and 4.

### 6 Press ►.

Program Play starts.

All the tracks play in the order you selected.

## To check the total number of programmed tracks

Press DISPLAY in stop mode. The total number of programmed steps appears, followed by the last programmed track number and the total playing time of the program.

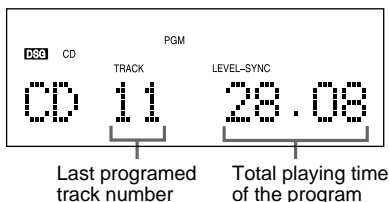

## To check the program order

Press ◀◀ or ▶▶ repeatedly during Program Play.

To	Do this
Cancel Program Play	Press ■, then press PLAY MODE repeatedly until “PGM” and “SHUFFLE” disappear.
Add a track to the program (in stop mode)	Perform steps 3 and 4.
Erase the entire program	Press ■, when Program Play is in stop mode.

## To select the desired track using the number buttons on the remote

Press number buttons instead of performing steps 3 to 5.

To enter track numbers 10 or over, press >10 and the track number. To enter 0, use the 10/0 button.

## Tips

- The program you made remains after Program Play finishes. To play the same program again, press ►.
- “Step Full” appears when you try to program 26 or more tracks (steps).
- “-.-” appears when the total CD program time exceeds 100 minutes, or when you select a CD track whose number is 21 or over.



# Using the CD display

You can check the total number of tracks, the total playing time and the remaining time on the current track or on the CD. When a CD TEXT disc is loaded, you can check the information recorded on the disc, such as the titles or artist names.

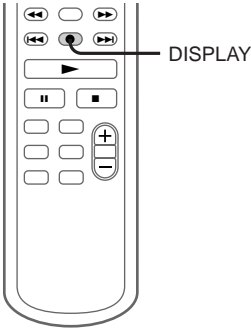

## In stop mode

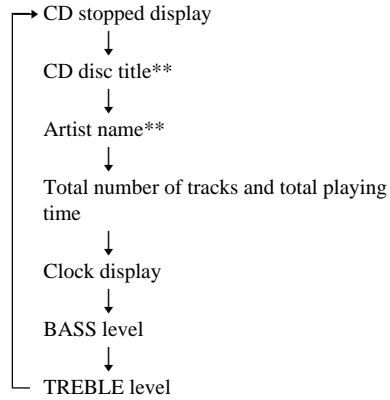

\* The remaining time of the program appears during Program Play.

\*\* If a CD that has no title is loaded, nothing appears. When the CD contains more than 50 tracks, CD TEXT is not displayed from track 51 on.

## ➔ Press DISPLAY.

Each time you press the button during normal play or in stop mode, the display changes as follows:

## During normal play

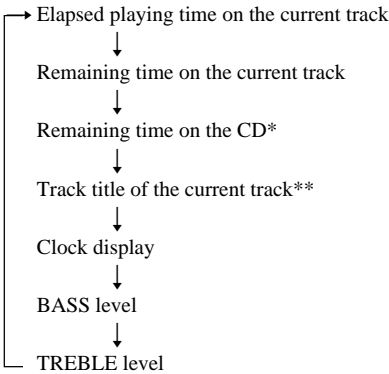

# Labeling a CD — Disc Memo

You can label up to 50 CDs with titles of up to 20 symbols and characters. Whenever you load a labeled CD, the title appears in the display.

## Notes

- You cannot label a CD for which “CD-TEXT” appears in the display.
- **When labeling CDs for the first time, be sure to perform the operations in “Erasing all disc titles stored in the system memory” on page 27 beforehand.**

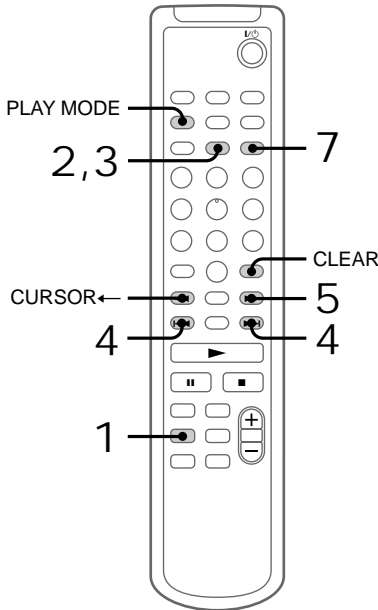

- 1 Press CD to switch the function to CD. Make sure the total number of tracks and the total playing time appear in the display in stop mode. If “SHUFFLE” or “PGM” appears in the display, press PLAY MODE repeatedly until both disappear.

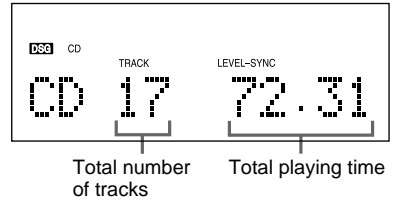

- 2 Press NAME EDIT. The cursor starts flashing.

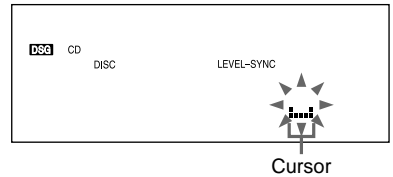

- 3 Press CHARACTER to select the desired type of character. Each time you press the button, the display changes as follows:  
 □ (Blank space)\* → A (Upper cases) → a (Lower cases) → 0 (Numbers) → ! (Symbols) → □ (Blank space)\* → ...  
 \* You cannot enter a space as the first character. For this reason, “□” (blank space) does not appear in the display when inputting the first character.

- 4 Press **◀** or **▶** repeatedly to select the desired character.

To enter a blank space

Press **CURSOR**→ without pressing **◀** or **▶**.

To enter a symbol

You can use the following 24 symbols.

! " # \$ % & ' ( ) \* + , - . / : ; < = > ? @ \_ `

- 5 Press **CURSOR**→.

The character you selected in step 4 stops flashing and the cursor shifts to the right.

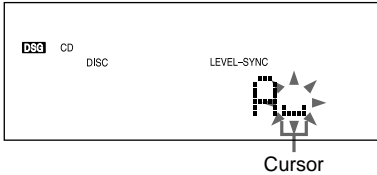

- 6 Repeat steps 3 to 5 to complete the entire title.

If you made a mistake

Press **CURSOR**← or **→** until the character you want to change flashes, then repeat steps 3 to 5.

To erase a character

Press **CLEAR** while the character is flashing. You cannot insert characters.

- 7 Press **ENTER/YES** to complete the labeling procedure.

The disc title is stored in the system memory and then the original display appears.

To cancel labeling

Press **MENU/NO**.

## Checking the disc titles

- 1 Press **MENU/NO** in stop mode.
- 2 Press **◀** or **▶** repeatedly until "Name Check ?" appears, then press **ENTER/YES**.
- 3 Press **◀** or **▶** repeatedly to select the disc titles stored in the system memory between 001 and 050.

To check the current disc title

Press **SCROLL** in stop mode.

## Erasing a disc title

- 1 Press **MENU/NO** in stop mode.
- 2 Press **◀** or **▶** repeatedly until "Name Erase ?" appears, then press **ENTER/YES**.  
The disc title appears scrolling in the display. "No Name" appears if no disc title is labeled.
- 3 Press **ENTER/YES** again.  
"Complete !!" appears and the disc title is erased.

To cancel erasing

Press **MENU/NO** during steps 1 and 2.

## Erasing all disc titles stored in the system memory

- 1 Press **MENU/NO** in stop mode.
- 2 Press **◀** or **▶** repeatedly until "All Erase ?" appears, then press **ENTER/YES**.  
"All Erase ??" appears.
- 3 Press **ENTER/YES** again to erase disc titles.  
"Complete !!" appears and all disc titles are erased.

To cancel erasing

Press **MENU/NO** during steps 1 and 2.

Note

To ensure that disc titles are not erased from memory, have the system connected to wall outlet at least once a month.

## Playing MD tracks repeatedly — Repeat Play

You can repeat an MD in normal play, Shuffle Play and Program Play.

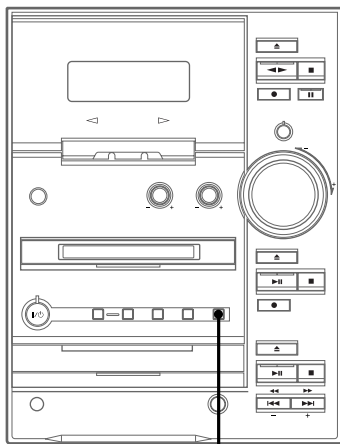

REPEAT

➔ Press REPEAT during play until “REPEAT” or “REPEAT 1” appears.

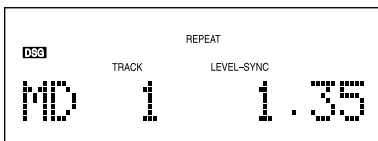

REPEAT: For all the tracks on the MD.

REPEAT 1\*: For a single track only.

\* You cannot repeat a single track during Shuffle Play or Program Play.

### To cancel Repeat Play

Press REPEAT until “REPEAT” or “REPEAT 1” disappears.

## Playing MD tracks in random order — Shuffle Play

You can play all the tracks on an MD in random order.

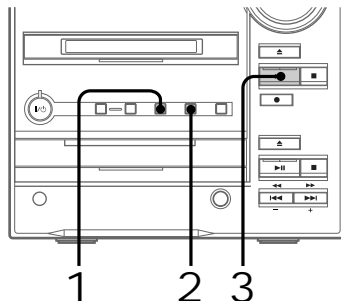

- 1 Press FUNCTION repeatedly to switch the function to MD.
- 2 Press PLAY MODE repeatedly until “SHUFFLE” appears in stop mode.

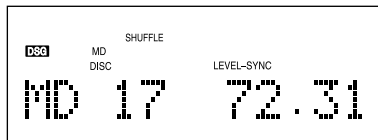

- 3 Press MD . Shuffle Play starts.

### To cancel Shuffle Play

Press MD to stop Shuffle Play, then press PLAY MODE repeatedly until “SHUFFLE” and “PGM” disappear.

### Tip

To skip a track, press .

# Programming MD tracks

## — Program Play

You can make a program up to 25 tracks in the order you want them to be played.

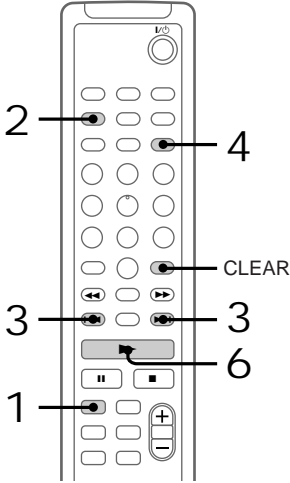

1 Press MD to switch the function to MD.

2 Press PLAY MODE repeatedly until “PGM” appears in stop mode.

3 Press ◀◀ or ▶▶ repeatedly until the desired track number appears in the display.

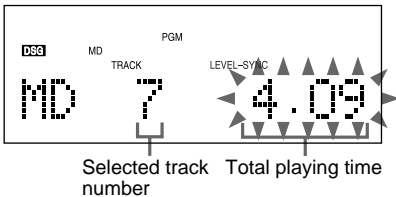

4 Press ENTER/YES.

The track is programmed.

“Step” appears, followed by the number of the track in the programmed sequence. The number of the last programmed track appears, followed by the total playing time of the program. If you have made a mistake, you can clear the last programmed track from the program by pressing CLEAR.

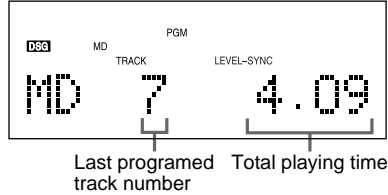

5 To program additional tracks, repeat steps 3 and 4.

6 Press ▶.

Program Play starts.

All the tracks play in the order you selected.

To check the total number of programmed tracks

Press DISPLAY in stop mode. The total number of programmed steps appears.

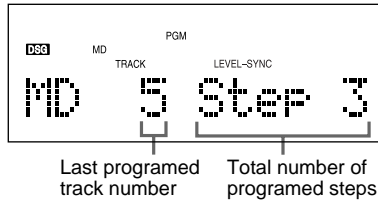

*continued*

## Programing MD tracks (continued)

To check the program order

Press ◀◀ or ▶▶ repeatedly during Program Play.

To	Do this
Cancel Program Play	Press ■, then press PLAY MODE repeatedly until “PGM” and “SHUFFLE” disappear.
Add a track to the program (in stop mode)	Perform steps 3 and 4.
Erase the last programmed track	Press CLEAR in stop mode. Each time you press the button, the last programmed track is erased.

To select the desired track using the number buttons on the remote

Press number buttons instead of performing steps 3 to 5.

To enter track numbers 10 or over, press >10 (press twice to enter 100 or over) and the track number. To enter 0, use the 10/0 button.

### Tips

- The program you made remains after Program Play finishes. To play the same program again, press ▶.
- “ProgramFull!” appears when you try to program 26 or more tracks (steps).
- “----.-” appears when the total MD program time exceeds 200 minutes.

## Using the MD display

You can check the total number of tracks, the total playing time and the remaining time on the MD.

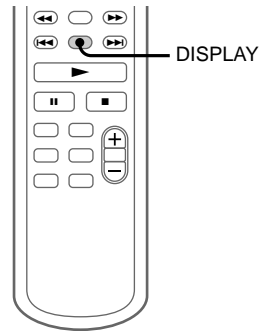

➔ Press DISPLAY.

Each time you press the button during normal play or in stop mode, the display changes as follows:

During normal play

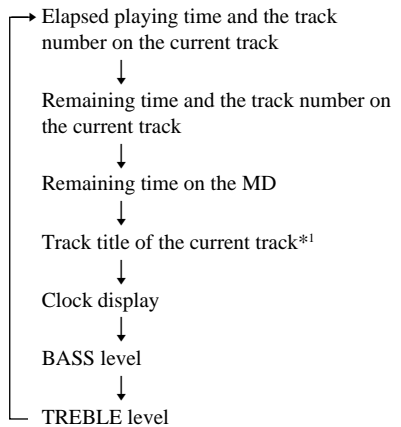

In stop mode

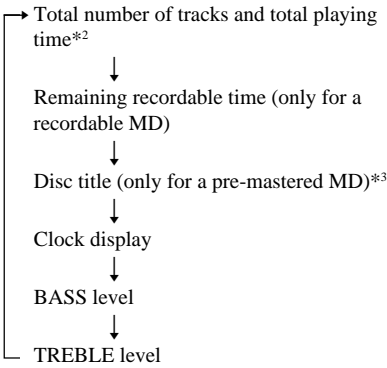

\*1 “No Name” appears when no track title is labeled.  
 \*2 “----” appears when the total MD program time exceeds 200 minutes.  
 \*3 “No Name” appears if no disc title is labeled.

Tips

- You can check a track title at any time during play. If you press SCROLL, a track title appears scrolling in the display. Press SCROLL at any point during the scroll display to stop the scrolling. Press SCROLL again to restart the scrolling.
- To label a disc title or a track title, see “Labeling an MD” on page 45.

## Before you start recording

MDs (Mini Disc) let you digitally record and play music with high quality sound. Another feature of MDs is track marking. The track marking feature lets you quickly locate a specific point or easily edit the recorded tracks. However, depending on the source you record, the recording method and the way the track numbers are recorded differ.

When the source you record from is:

- This system’s CD player
  - The MD deck performs digital recording.\*1
  - Track numbers are automatically marked as on the original CD.
- This system’s tuner and other components connected to the VIDEO IN jack (e.g., a VCR)
  - The MD deck performs analog recording.\*2
  - A track number is marked at the beginning of a recording, but when you turn on the Level Synchro Recording function (see page 37), track numbers are automatically marked in sync with the level of the input signal.

\*1 For details on the limitations of digital recording, see page 73.  
 \*2 Even if a digital component is connected to the VIDEO IN jack, the MD deck performs analog recording.

### Note on MD track numbers

On an MD, the track numbers (track sequence), track start and end point information, etc., are recorded in the TOC\*3 area independent of the sound information. You can edit recorded tracks quickly by modifying the TOC information.

\*3 TOC: Table Of Contents

continued

Before you start recording  
(continued)

## After recording

- ➔ Press MD ▲ to remove the MD or press I/⏻ (power) to turn off the system.  
“TOC” lights up, or either “TOC” or “STANDBY” starts flashing. The TOC is updated and recording is completed.

Before pulling out the power cord

MD recording is completed when the MD Table of Contents (TOC) is updated. The TOC is updated when you eject the MD or press I/⏻ to turn off the system. Do not pull out the power cord before updating the TOC (while “TOC” is lit) or while updating the TOC (while “TOC” or “STANDBY” is flashing) to ensure a complete recording.

Protecting a recorded MD

- To protect a recorded MD, slide the tab on the side of the MD to open the slot. In this position, the MD cannot be recorded. To record on the MD, slide the tab to close the slot.

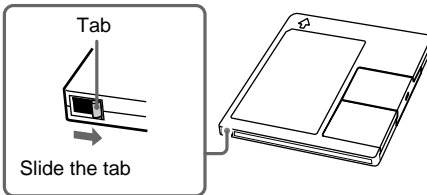

- If the MD is record protected, “C11” and “Protected” appear alternately and the MD cannot be recorded. Remove the MD, then slide the record protection tab to the closed position.

# Recording your favorite CD tracks on an MD

— CD-MD Synchro Recording

You can select your favorite CD tracks with the Program Play feature, then record the program on an MD using the CD Synchro Recording feature. If you use a partially recorded MD, recording starts after the recorded tracks.

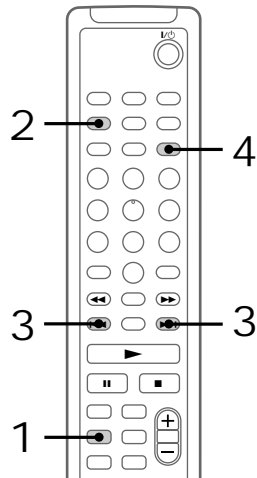
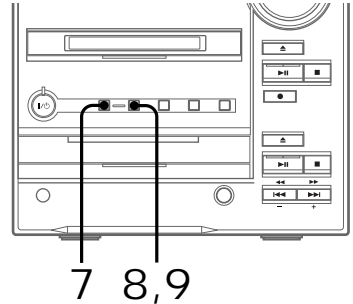



## Selecting the tracks

- 1 Press CD on the remote to switch the function to CD.
- 2 Press PLAY MODE on the remote repeatedly until “PGM” appears.
- 3 Press ◀◀ or ▶▶ on the remote repeatedly until the desired track number appears.

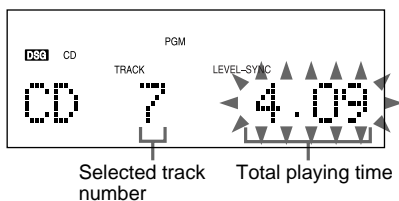

- 4 Press ENTER/YES on the remote. The track is programmed. “Step” appears, followed by the number of the track in the programmed sequence. The number of the last programmed track appears, followed by the total playing time of the program.

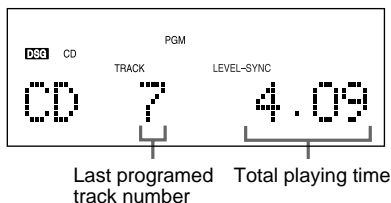

- 5 To program additional tracks, repeat steps 3 and 4.

## Recording on an MD

- 6 Insert a recordable MD.
- 7 Press SYNCHRO REC repeatedly until “CD-MD SYNC” appears.
- 8 Press ENTER/START. The MD deck stands by for recording and the CD player pauses for play.
- 9 Press ENTER/START again. CD playing and MD recording start. When the recording is completed, the CD player and the MD deck stop automatically.

### To stop recording

Press CD ■ or MD ■.

### If the MD becomes full during recording

The CD player and the MD deck stop automatically.

### To record on a tape at the same time

Insert a blank tape and select “DUAL SYNC” in step 7 of “Recording on an MD” on this page.

continued

## Recording your favorite CD tracks on an MD (continued)

Before pulling out the power cord

MD recording is completed when the MD Table of Contents (TOC) is updated. The TOC is updated when you eject the MD or press I/⏻ to turn off the system. Do not pull out the power cord before updating the TOC (while “TOC” is lit) or while updating the TOC (while “TOC” or “STANDBY” is flashing) to ensure a complete recording.

### Tip

The track numbers of the CD are recorded on to the MD automatically.

### Note

If “Cannot SYNC” appears, a disc is not loaded or you cannot record on that MD (see page 79).

## Labeling titles during recording

If “CD-TEXT” lights up or flashes during recording, you can record the CD TEXT information onto the MD as follows:

- Automatically during recording  
If you record on an unrecorded or completely erased (see page 48) MD when “CD-TEXT” is lit, the CD TEXT information is automatically recorded.
- Manually during recording  
When “CD-TEXT” flashes, press NAME EDIT on the remote, and then press ENTER/YES on the remote to record the title of the current track.

### Notes

- Depending on the disc, the CD TEXT information may not be recorded automatically.
- When you record on an MD and a tape at the same time, the CD TEXT information is not recorded. Record this information after the recording is completed (see page 45).

## Recording on an MD manually — Manual Recording

With manual recording, you can record just the portions you like from a CD, or start recording from the middle of the tape. You can also record a radio program.

If you use a partially recorded MD, recording starts after the recorded tracks.

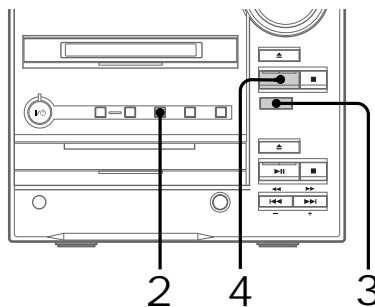

- 1 Insert a recordable MD.
- 2 Press FUNCTION repeatedly to select the desired source (e.g., TUNER) to record.
  - CD: Recording from the CD
  - TAPE: Recording from the tape
  - TUNER: Recording from the radio
- 3 Press MD REC ●.  
The MD deck stands by for recording.
- 4 Press MD ►||.  
Recording starts.

- 5 Start playing the desired source to record.

When recording from this system's CD player, the track numbers are automatically marked. Press MD REC ● during recording to mark the track numbers at the desired point. If you want to mark track numbers automatically during recording from the radio, see "Marking track numbers" on page 37.

## To stop recording

Press MD ■.

## Before pulling out the power cord

MD recording is completed when the MD Table of Contents (TOC) is updated. The TOC is updated when you eject the MD or press I/⏻ to turn off the system. Do not pull out the power cord before updating the TOC (while "TOC" is lit) or while updating the TOC (while "TOC" or "STANDBY" is flashing) to ensure a complete recording.

## Tips

- You can adjust the recording level to the desired volume (see page 41).
- You can check the remaining recordable time on the MD during recording by pressing DISPLAY on the remote.

## Note

If you pause recording during CD recording, a track number is assigned at that point. Also, note that only one track number might be assigned when the same single track of the same CD is recorded repeatedly.

# Starting recording with 6 seconds of prestored audio data

## — Time Machine Recording

When recording from an FM or satellite broadcast, the first few seconds of material are often lost due to the time it takes you to ascertain the contents and press the record button. To prevent the loss of this material, the Time Machine Recording feature constantly stores the most recent audio data in a buffer memory. This lets you record the sound from 6 seconds (12 seconds for monaural recording) before starting recording, as shown in the illustration below:

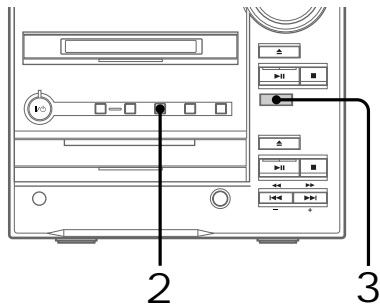
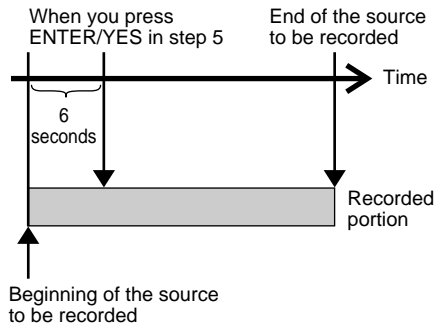

*continued*

*Starting recording with  
6 seconds of prestored audio  
data (continued)*

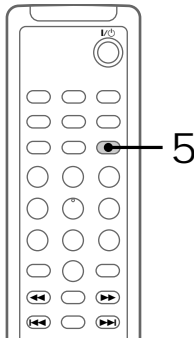

- 
- 1 Insert a recordable MD.

---

  - 2 Press FUNCTION repeatedly to select the desired source (i.e., TUNER) to record.

---

  - 3 Press MD REC ●.  
The MD deck stands by for recording.

---

  - 4 Start playing the desired source to record.

---

  - 5 Press ENTER/YES on the remote at the desired point to start recording.  
Recording of the source starts with the 6 seconds of audio data stored in the buffer memory.  
If you use a partially recorded MD, recording starts after the recorded tracks.
- 

To stop Time Machine Recording  
Press MD ■.

Before pulling out the power cord

MD recording is completed when the MD Table of Contents (TOC) is updated. The TOC is updated when you eject the MD or press I/⏻ to turn off the system. Do not pull out the power cord before updating the TOC (while “TOC” is lit) or while updating the TOC (while “TOC” or “STANDBY” is flashing) to ensure a complete recording.

**Note**

The MD deck starts storing audio data when the deck stands by for recording in step 3 and you start playing the source. If less than 6 seconds have passed when you press ENTER/YES on the remote, Time Machine Recording starts with less than 6 seconds of audio data.

# Marking track numbers

You can mark track numbers as follows:

## • Automatically during recording

Track numbers are automatically marked as on the original source during recording from this system's CD player. Use the Level Synchro Recording function to automatically mark track numbers during recording from this system's tuner or components connected to the VIDEO IN jack.

However, you cannot mark track numbers automatically if the sound source to be recorded is noisy (e.g., tapes or radio programs) or during timer-recording.

## • At any point during recording

You can mark track numbers during recording of any source.

## • After recording

Use the Divide Function (see page 52).

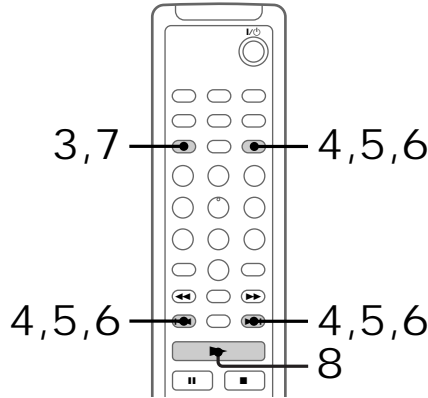
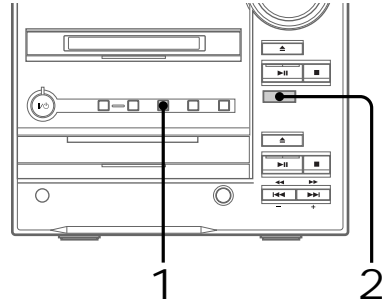

## Marking track numbers automatically during recording — Level-Synchro Recording

The Level Synchro Recording function is factory set to on, so the track numbers are automatically marked. If “LEVEL-SYNC” does not appear during recording, turn on the Level Synchro Recording as follows. Track numbers are automatically marked when the input signal is continuously below a certain level for more than 2 seconds and then exceeds that level.

### Note

You cannot mark track numbers automatically if the sound source to be recorded is noisy (e.g., tapes or radio programs).

- 1 Press **FUNCTION** repeatedly to switch the function to **TUNER**.  
To record from other components connected to this system, select “**VIDEO**”.
- 2 Press **MD REC** ●.  
The MD deck stands by for recording.
- 3 Press **MENU/NO** on the remote.
- 4 Press **◀◀** or **▶▶** on the remote repeatedly until “**Setup ?**” appears, then press **ENTER/YES** on the remote.

continued

## Marking track numbers (continued)

- 5 Press ◀◀ or ▶▶ repeatedly until “T.Mark Off” appears, then press ENTER/YES.
- 6 Press ◀◀ or ▶▶ repeatedly until “T.Mark LSync” appears, then press ENTER/YES.  
“LEVEL-SYNC” lights up.
- 7 Press MENU/NO.
- 8 Press ▶ on the remote.  
Recording starts.

### To stop recording

Press MD ■.

### To cancel automatic track marking

- 1 Press MENU/NO on the remote during recording pause.
- 2 Press ◀◀ or ▶▶ on the remote repeatedly until “Setup ?” appears, then press ENTER/YES on the remote.
- 3 Press ◀◀ or ▶▶ repeatedly until “T.Mark LSync” appears, then press ENTER/YES.
- 4 Press ◀◀ or ▶▶ repeatedly until “T.Mark Off” appears, then press ENTER/YES.  
“LEVEL-SYNC” lights off.
- 5 Press MENU/NO.

When “LEVEL-SYNC” is off, a track number is marked only at the beginning of each recording.

## Marking track numbers at a specific point during recording — Track Mark

You can mark track numbers at any time during recording, regardless of the type of sound source.

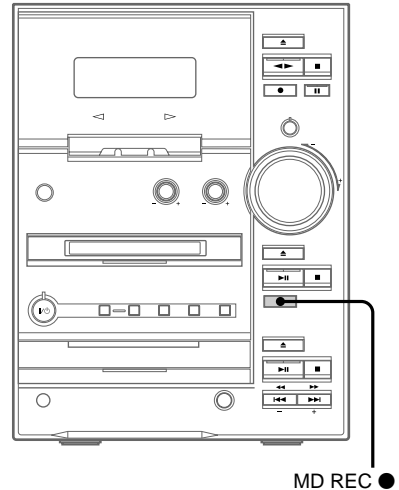

- ➔ Press MD REC ● during recording at the point you want to add a track mark. The tracks following the added one are renumbered.

# Making a space between tracks 3 seconds long — Smart Space

The Smart Space function lets you make the blank spaces between tracks 3 seconds long automatically while making a digital recording from a CD. For other types of recording, if the Smart Space function is on and there is no sound input for about 3 seconds or more (but less than 30 seconds) while recording, the MD deck replaces this silence with a blank of about 3 seconds and continues recording.

No sound input for less than 30 seconds

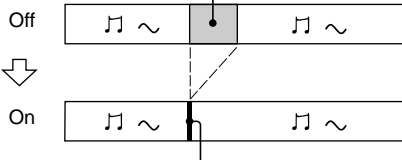

Replaced with a blank of 3 seconds and recording continues

**Auto Cut:** When the Smart Space function is on, if there is no sound input for 30 seconds or more, the MD deck replaces this silence with a blank of about 3 seconds and enters recording pause.

No sound input for 30 seconds or more

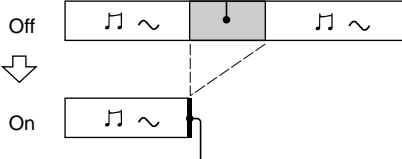

Replaced with a blank of 3 seconds and recording pauses

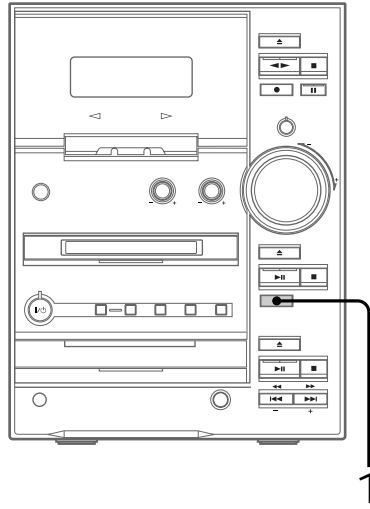

The MD Deck — Recording

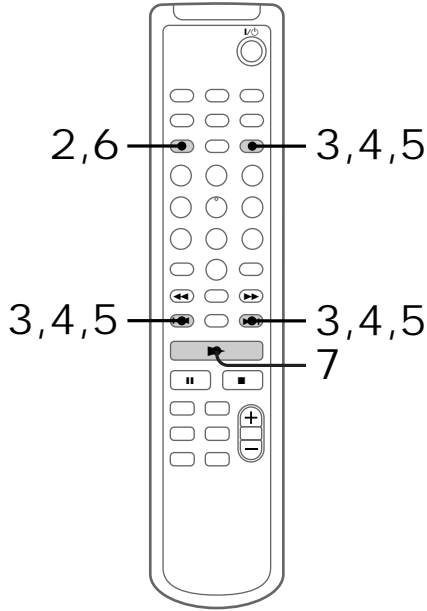

1 Press MD REC ● to stand by for recording.

2 Press MENU/NO on the remote.

*continued*

### Making a space between tracks 3 seconds long (continued)

---

3 Press **◀◀** or **▶▶** on the remote repeatedly until “Setup ?” appears, then press ENTER/YES on the remote.

---

4 Press **◀◀** or **▶▶** repeatedly until “S.Space Off” (or “S.Space On”) appears, then press ENTER/YES.

---

5 Press **◀◀** or **▶▶** repeatedly until “S.Space On” appears, then press ENTER/YES.

---

6 Press MENU/NO.

---

7 Press **▶** on the remote.  
Recording starts.

---

8 Start playing the desired source to record.

If there is an extended silence of less than 30 seconds, “Smart Space” appears, and the MD deck replaces the silence with a blank of about 3 seconds and continues recording.

If there is no sound input for 30 seconds or more, “Auto Cut” appears, and the MD deck replaces the silence with a blank of about 3 seconds and switches to recording pause.

Press **▶** to restart the recording.

---

### To stop recording

Press MD **■**.

### To turn off Smart Space and Auto Cut functions

1 Press MENU/NO on the remote during recording pause.

2 Press **◀◀** or **▶▶** on the remote repeatedly until “Setup ?” appears, then press ENTER/YES on the remote.

3 Press **◀◀** or **▶▶** repeatedly until “S.Space On” appears, then press ENTER/YES.

4 Press **◀◀** or **▶▶** repeatedly until “S.Space Off” appears, then press ENTER/YES.

5 Press MENU/NO.

#### Tip

The Smart Space and Auto Cut functions are factory set to on. If you turn off the system or disconnect the power cord, the MD deck will retain the last setting (S.Space On or Off).



# Adjusting the recording level

When recording on an MD, you can adjust the recording level to the desired volume. You can adjust the recording level not only when making an analog recording, but also when making a digital recording from a CD, etc.

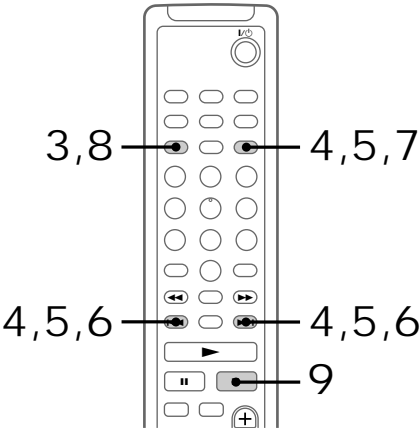
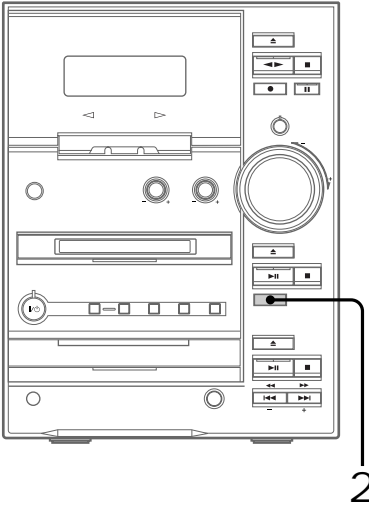

- 1 Prepare the desired sound source to record and start play.
- 2 Confirm that the MD deck is in recording standby.  
If not, press MD REC ●.
- 3 Press MENU/NO on the remote.
- 4 Press ◀◀ or ▶▶ on the remote repeatedly until "Setup ?" appears, then press ENTER/YES on the remote.
- 5 Press ◀◀ or ▶▶ repeatedly until "LevelAdjust?" appears, then press ENTER/YES.
- 6 Press ◀◀ or ▶▶ to adjust the recording level.

The recording level can be adjusted from -12 to +12. While monitoring the sound, adjust to the optimum level while making sure that "OVER" does not appear in the display at the loudest portion. The level meter appears in the display while adjusting the level. (The left channel is on the top, and the right channel is on the bottom.)

Adjust the level not to appear "OVER"

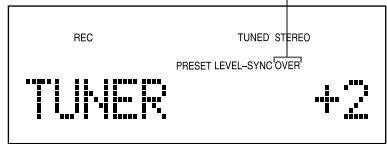

*continued*

## Adjusting the recording level (continued)

- 7 Press ENTER/YES.
- 8 Press MENU/NO.
- 9 Press **■** on the remote.

### To stop recording

Press MD **■**.

### Tips

- You can also adjust the recording level during recording.
- Once adjusted, the recording level is maintained until you adjust it again.

## Monaural recording

Stereo signals such as an FM stereo broadcast can be converted to monaural format and recorded. When recording in monaural format, the MD recording time is approximately twice the normal recording (stereo recording) time (i.e., 120 minutes of monaural audio can be recorded on a 60-minute MD).

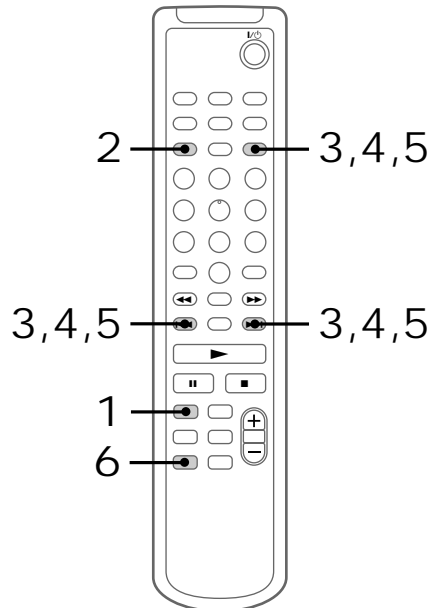
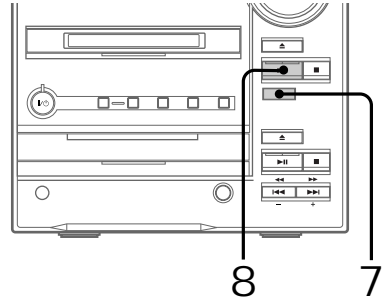

- 1 Press MD on the remote to switch the function to MD.
- 2 Press MENU/NO on the remote in stop mode.
- 3 Press ◀◀ or ▶▶ on the remote repeatedly until “Setup ?” appears, then press ENTER/YES on the remote.
- 4 Press ◀◀ or ▶▶ repeatedly until “Stereo Rec” (or “Mono Rec”) appears, then press ENTER/YES.
- 5 Press ◀◀ or ▶▶ repeatedly until “Mono Rec” appears, then press ENTER/YES.  
“MONO” lights up.
- 6 Press FUNCTION repeatedly to select the desired source (e.g., TUNER) to record.
- 7 Press MD REC ●.  
The MD deck stands by for recording.
- 8 Press MD ▶▶||.  
Recording starts.  
The sound source is heard as is (e.g., stereo sound when recording a stereo broadcast) from the speakers.

### To stop recording

Press MD ■.

### To return to stereo recording

- 1 Press MENU/NO on the remote when MD function is in stop mode.
- 2 Press ◀◀ or ▶▶ on the remote repeatedly until “Setup ?” appears, then press ENTER/YES on the remote.
- 3 Press ◀◀ or ▶▶ repeatedly until “Mono Rec” appears, then press ENTER/YES.
- 4 Press ◀◀ or ▶▶ repeatedly until “Stereo Rec” appears, then press ENTER/YES.  
The system switches back to stereo recording, and “MONO” lights off.

## Before you start editing

You can edit the recorded tracks on an MD. By using the editing functions, you can create a new sequence to the recorded MD.

### Editing functions

- **Name — Labeling MDs (page 45)**  
Use this function to label discs and tracks. You can use upper case, lower case, numbers, and symbols for the titles.
- **Erase — Erasing recordings (page 47)**  
Use this function to erase a single track one by one, all the tracks at once, or a portion of a track.
- **Move — Changing the order of tracks (page 51)**  
Use this function to change the track numbering.
- **Divide — Adding track numbers (page 52)**  
Use this function to add track numbers. This lets you locate your favorite phrases quickly.
- **Combine — Combining recorded tracks (page 53)**  
By using this function, two tracks are combined to a single track. You can combine the tracks which are not numerically consecutive, i.e. the track 1 and track 4, etc.
- **Undo — Canceling the last edit (page 55)**  
Use this function to cancel the last edit and restore the contents of the MD to the condition before the edit.

### Before editing

You can edit an MD only when:

- The MD is recordable.
- The MD play mode is normal play.

Check the following, before editing.

**1** Check the tab of the MD to be edited.  
If the MD is record protected, “C11” and “Protected” appear alternately and the MD cannot be edited.  
Slide the tab to close the slot.

**2** Press PLAY MODE repeatedly until both “PGM” and “SHUFFLE” disappear.  
You can edit the MD only in normal play mode. You cannot edit the MD in Shuffle or Program Play.

### After editing

- ➔ Press MD  to remove the MD or press I/⏻ (power) to turn off the system.  
“TOC” lights up, or either “TOC” or “STANDBY” starts flashing. The TOC is updated and editing is completed.

Before pulling out the power cord

MD editing is completed when the MD Table of Contents (TOC) is updated. The TOC is updated when you eject the MD or press I/⏻ to turn off the system. Do not pull out the power cord before updating the TOC (while “TOC” is lit) or while updating the TOC (while “TOC” or “STANDBY” is flashing) to ensure a complete editing.

# Labeling an MD

## — Name Function

You can create titles for your recorded MDs and tracks as follows.

### During recording

If "CD-TEXT" lights up or flashes in the display during recording a CD, you can record the CD disc title on the MD (see page 34). However, the CD disc title is not recorded when recording a CD on an MD and a tape at the same time.

### After recording

Use Name Function on this page. You can input a total of approximately 1700 characters for the disc title and track titles on a single MD.

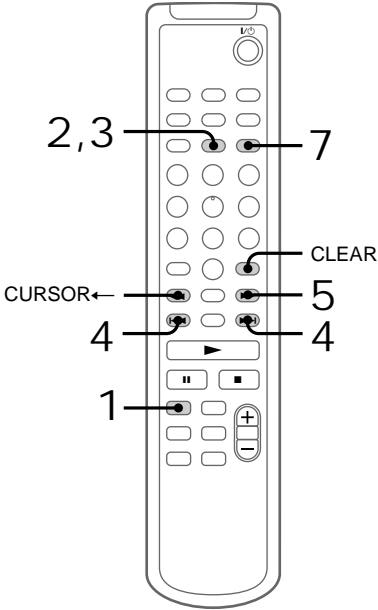

- 1 Press MD to switch the function to MD.  
To label a track, press ◀◀ or ▶▶ repeatedly until the desired track number appears.

- 2 Press NAME EDIT.  
The cursor starts flashing.

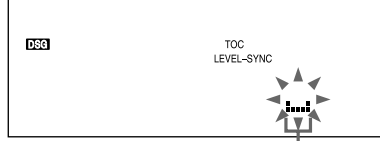

Cursor

- 3 Press CHARACTER to select the desired type of character.  
Each time you press the button, the display changes as follows:  
 ◻ (Blank space)\* → A (Upper cases) → a (Lower cases) → 0 (Numbers) → ! (Symbols) → ◻ (Blank space)\* → ...  
 \* You cannot enter a space as the first character. For this reason, "◻" (blank space) does not appear in the display when inputting the first character.

- 4 Press ◀◀ or ▶▶ repeatedly to select the desired character.

To enter a blank space  
Press CURSOR→ without pressing ◀◀ or ▶▶.

To enter a symbol  
You can use the following 24 symbols.

! " # \$ % & ' ( ) \* + , - . / : ; < = > ? @ \_ `

continued

**5** Press CURSOR→.

The character you selected in step 4 stops flashing and the cursor shifts to the right.

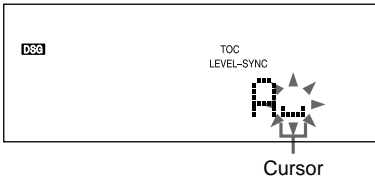

**6** Repeat steps 3 to 5 to complete the entire title.

If you made a mistake

Press CURSOR← or → until the character you want to change flashes, then repeat steps 3 to 5.

To erase a character

Press CLEAR while the character is flashing. You cannot insert characters.

**7** Press ENTER/YES to complete the labeling procedure.

The titles you labeled appear sequentially, and then the original display appears.

To cancel labeling

Press MENU/NO.

Notes

- You can label a track title during play. The playback repeats until you finish labeling.
- If the MD is record protected, "C11" and "Protected" appear alternately and the MD cannot be edited. Remove the MD, then slide the record protection tab to the closed position (see page 32).

## Copying a disc or track title

You can copy a labeled disc or track title to use it as a title of another track or the disc title within a disc.

- 1 Press MENU/NO in stop mode.
- 2 Press ◀◀ or ▶▶ repeatedly until "Name ?" appears, then press ENTER/YES.
- 3 Press ◀◀ or ▶▶ repeatedly until "Nm Copy ?" appears, then press ENTER/YES.
- 4 Press ◀◀ or ▶▶ repeatedly to select "Disc" (when copying the disc title) or the track number with the title you want to copy, then press ENTER/YES.

**When "No Name" appears**

The disc or track has not been labeled.

- 5 Press ◀◀ or ▶▶ repeatedly to select the copy destination track number or "Disc" (when copying as the disc title), then press ENTER/YES.

**When "Overwrite ??" appears**

The copy destination already has a disc or track title. To continue and copy the title, press ENTER/YES.

To cancel copying

Press MENU/NO.

## Checking the titles

To check the disc titles, press SCROLL in stop mode. To check the track title, press SCROLL during play. The title appears scrolling in the display. To stop scrolling, press SCROLL. Press the button again to resume scrolling.

## Erasing the titles

- 1 Press MENU/NO in stop mode.
- 2 Press ◀◀ or ▶▶ repeatedly until “Name ?” appears, then press ENTER/YES.
- 3 Press ◀◀ or ▶▶ repeatedly until “Nm Erase?” appears, then press ENTER/YES.  
To erase all the titles, press ◀◀ or ▶▶ repeatedly until “Nm All Ers?” appears, then press ENTER/YES.  
“Nm All Ers?” appears.
- 4 Press ◀◀ or ▶▶ repeatedly until the desired title to erase appears, then press ENTER/YES.  
To erase all the titles, press ENTER/YES again.  
“Complete !!” appears and the title is erased.

### To cancel erasing

Press MENU/NO.

### To return to the condition before labeling or erasing

You can return to the original condition immediately after labeling or erasing a title by using Undo Function on page 55.

## Erasing recordings

### — Erase Function

The MD deck lets you erase unwanted tracks quickly and easily. You can restore the contents to the condition before erasing (unerase) by using the Undo function. Note, however, you cannot undo an edit after performing any additional edits.

The three options for erasing recordings are:

- Erasing a single track (Track Erase Function)
- Erasing all tracks (All Erase Function)
- Erasing a portion of a track (A-B Erase Function)

### Erasing a single track

#### — Track Erase Function

You can erase a track simply by selecting its track number. When you erase a track, the total number of tracks on the MD decreases by one and all the tracks following the erased one are renumbered.

Example: Erasing track 2.

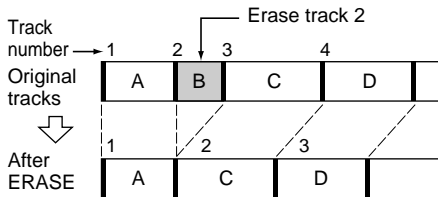

When erasing multiple tracks, you should proceed in order from high to low track number to prevent the renumbering of tracks that have not been erased yet.

continued

## Erasing recordings (continued)

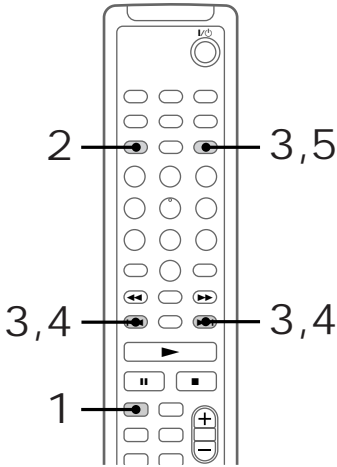

- 1 Press MD to switch the function to MD.
- 2 Press MENU/NO to display “Edit Menu”.
- 3 Press ◀◀ or ▶▶ repeatedly until “Tr Erase?” appears, then press ENTER/YES.
- 4 Press ◀◀ or ▶▶ repeatedly until the desired track number appears.

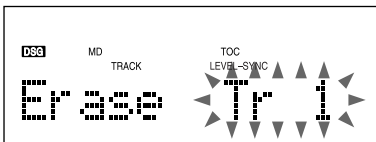

- 5 Press ENTER/YES.  
“Complete !!” appears for a few seconds and the selected track and title are erased.

To cancel erasing

Press MENU/NO.

To return to the condition before ERASE

You can return to the original condition immediately after erasing the tracks by using Undo Function on page 55.

Note

“Erase???” appears when the track was recorded or edited on another deck and then protected. To erase the track, press ENTER/YES while “Erase???” appears.

## Erasing all tracks — All Erase Function

You can erase the disc title, all recorded tracks and their titles at once.

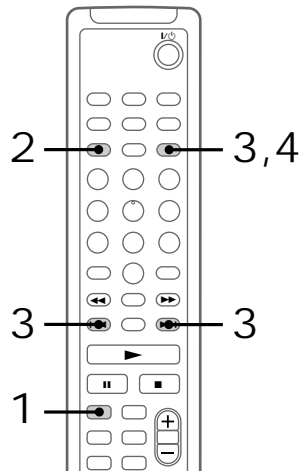

- 1 Press MD to switch the function to MD.
- 2 Press MENU/NO to display “Edit Menu”.



- Press **⏮** or **⏭** repeatedly until “All Erase ?” appears, then press ENTER/YES.  
“All Erase ??” appears.

- Press ENTER/YES again.  
“Complete !!” appears for a few seconds and the disc title, all recorded tracks and their titles are erased.

To cancel erasing

Press MENU/NO.

To return to the condition before ERASE

You can return to the original condition immediately after erasing the tracks by using Undo Function on page 55.

## Erasing a portion of a track

### — A-B Erase Function

You can specify a portion within a track and erase the portion with ease. You can shift the desired portion by frame\*, minute or second intervals. This function is convenient when erasing unnecessary sections after recording a satellite broadcast or FM broadcast.

\* 1 frame is 1/86 second.

Example: Erasing a portion of track 2.

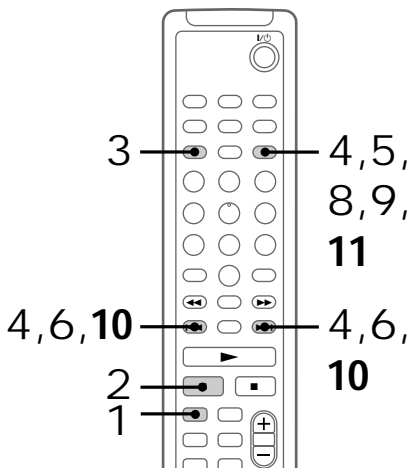
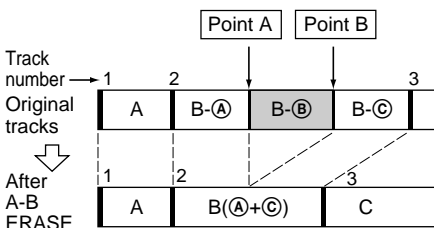

- Press MD to switch the function to MD.
- While playing an MD, press **⏸** at the starting point of the portion to be erased (point A).  
The MD pauses.
- Press MENU/NO to display “Edit Menu.”
- Press **⏮** or **⏭** repeatedly until “A-B Erase ?” appears, then press ENTER/YES.

- Press ENTER/YES again.  
“—Rehearsal—” and “Point A ok?” appear alternately while the deck plays the selected track from the beginning to point A.

*continued*

- 
- 6** While monitoring the sound, press **⏮** or **⏭** repeatedly to find the starting point of the portion to be erased (point A).

You can shift the starting point by 1/86 second (1 frame) intervals.

To shift the point by second or minute intervals, press **⏪** or **⏩** so that second or minute flashes, then press **⏮** or **⏭**.

- 
- 7** Repeat step 6 until point A is played correctly.

- 
- 8** Press ENTER/YES if point A is correct. "Point B Set" appears and playback for setting the ending point of the portion to be erased (point B) starts.

- 
- 9** Continue playback until the deck reaches point B, then press ENTER/YES. "A-B Ers" and "Point B ok?" appear alternately and the deck repeats a portion of the few seconds before point A and after point B successively.

- 
- 10** Press **⏮** or **⏭** repeatedly to find point B. The procedure is the same as step 6.

- 
- 11** Press ENTER/YES if point B is correct. "Complete !!" appears for a few seconds and the portion between point A and B is erased.
- 

To cancel erasing

Press MENU/NO.

To return to the condition before ERASE

You can return to the original condition immediately after erasing the tracks by using Undo Function on page 55.

Note

If "Impossible" appears, the specified portion cannot be erased. This happens when you have edited the same track many times. This is due to a technical limitation of the MD system and is not a mechanical error.

# Moving recorded tracks

## — Move Function

You can use this function to change the order of any track on the disc. When you move tracks, the tracks are automatically renumbered.

Example: Moving track 3 to position 2.

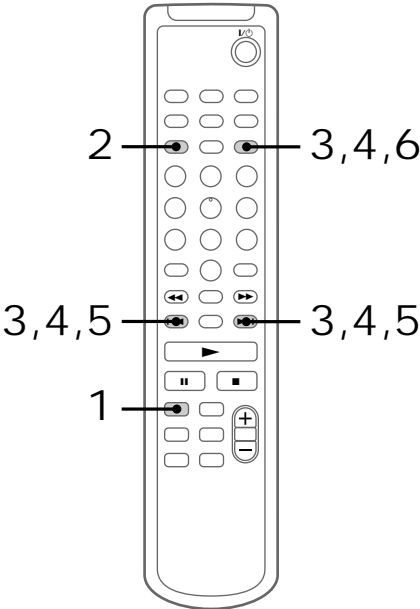
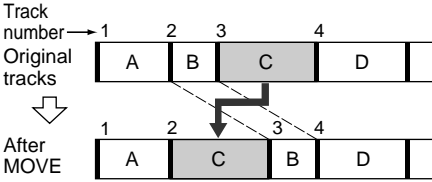

- 1 Press MD to switch the function to MD.
- 2 Press MENU/NO to display “Edit Menu.”
- 3 Press ◀◀ or ▶▶ repeatedly until “Move ?” appears, then press ENTER/YES.
- 4 Press ◀◀ or ▶▶ repeatedly until the desired track number to move appears, then press ENTER/YES.
- 5 Press ◀◀ or ▶▶ repeatedly until the new track position appears.

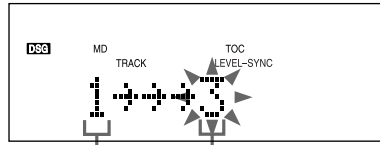

- 6 Press ENTER/YES.  
“Complete !!” appears for a few seconds and the selected track moves to the appointed position.

To cancel moving

Press MENU/NO.

To return to the track order before MOVE

You can return to the original track order immediately after moving recorded tracks by using Undo Function on page 55.

# Dividing recorded tracks

## — Divide Function

You can use this function to mark track numbers after recording. The total number of tracks increases by one and all the tracks following the divided ones are renumbered.

Example: Dividing track 2 into two tracks.

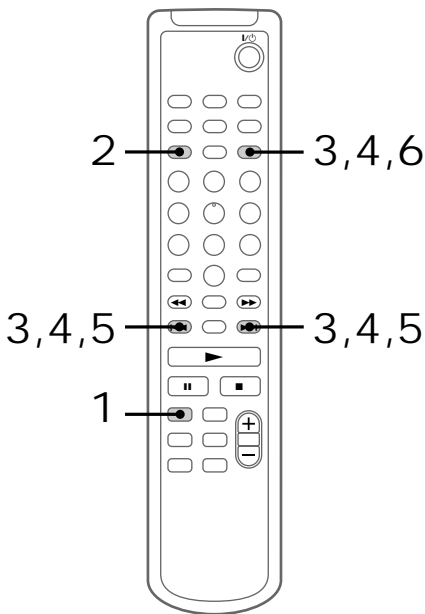
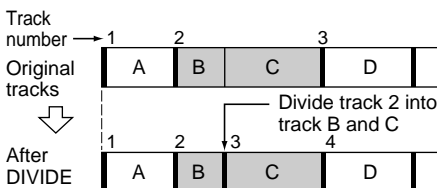

1 Press MD to switch the function to MD.

2 Press MENU/NO to display “Edit Menu.”

3 Press ◀◀ or ▶▶ repeatedly until “Divide ?” appears, then press ENTER/YES.

4 Press ◀◀ or ▶▶ repeatedly until the desired track number to divide appears, then press ENTER/YES.

“—Rehearsal—” appears and the portion to be divided is played repeatedly.

5 While monitoring the sound, press ◀◀ or ▶▶ repeatedly to adjust the point to be divided.

You can shift the point by 1/86 second (1 frame) intervals.

To shift the point by second or minute intervals, press ◀◀ or ▶▶ so that second or minute flashes, then press ◀◀ or ▶▶.

6 Press ENTER/YES.

“Complete !!” appears for a few seconds and the newly created track starts playing.

To cancel dividing

Press MENU/NO.

To return to the condition before DIVIDE

You can return to the original condition immediately after dividing the tracks by using Undo Function on page 55. You can also return to the original condition by using Combine Function on page 53.

## Notes

- If you divide a labeled track (see page 45) into two tracks, only the first track retains the track title.

Example:



The new track is not labeled

- “Impossible” appears, when you specify the division point at the beginning or end of a track. Press **◀◀** or **▶▶** to shift the position.

## Combining recorded tracks — Combine Function

You can use this function to combine 2 tracks into a single track. The total number of tracks decreases by one and all tracks following the combined ones are renumbered.

You can also use this function to erase unnecessary track numbers.

Example: Combining track 3 to track 1.

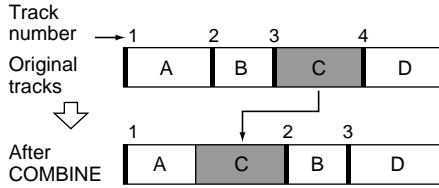

Example: Combining track 1 to track 4.

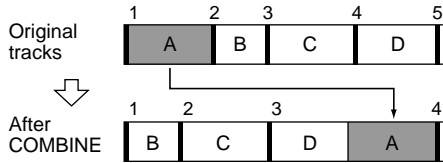

*continued*

## Combining recorded tracks (continued)

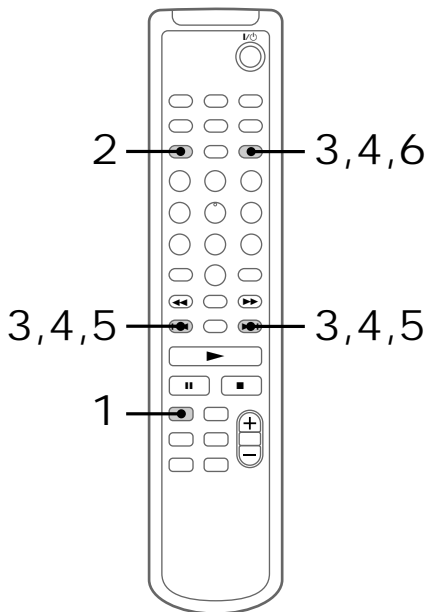

1 Press MD to switch the function to MD.

2 Press MENU/NO to display “Edit Menu.”

3 Press ◀ or ▶ repeatedly until “Combine ?” appears, then press ENTER/YES.

4 Press ◀ or ▶ repeatedly until the first track number of the two to be combined appears, then press ENTER/YES.

For example, to combine tracks 4 and 1, select 4.

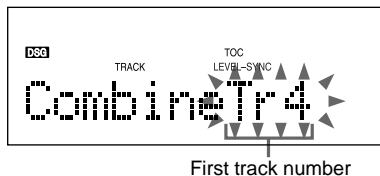

5 Press ◀ or ▶ repeatedly until the second track number of the two to be combined appears.

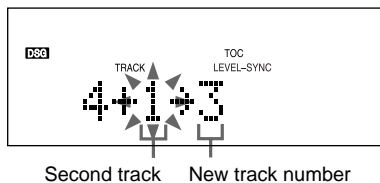

6 Press ENTER/YES.  
“Complete !!” appears for a few seconds and the tracks are combined. Play starts.

To cancel combining  
Press MENU/NO.

To return to the condition before  
COMBINE

You can return to the original condition immediately after combining the tracks by using Undo Function on page 55. You can also return to the original condition by using Divide Function on page 52.

## Notes

- If both of the combined tracks have track titles, the title of the second track is erased.
- If “Impossible” appears, the tracks cannot be combined. This happens when you have edited the same track many times. This is due to a technical limitation of the MD system and is not a mechanical error.

---

# Undoing the last edit

## — Undo Function

You can use this function to cancel the last edit and restore the contents of the MD to the condition before the edit.

Note, however, that you cannot undo an edit if you do any of the following after the edit:

- Do another edit.
- Press the MD REC ● or ENTER/START button.
- Update the TOC by turning off the system or ejecting the MD.
- Disconnect the power cord.

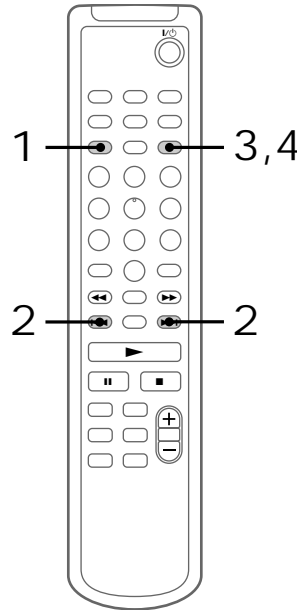

continued

- 1 Press MENU/NO in stop mode to display "Edit Menu."
- 2 Press ◀◀ or ▶▶ repeatedly until "Undo ?" appears.  
"Undo ?" does not appear, when there is no editing function that can be canceled.

- 3 Press ENTER/YES.  
One of the following messages appears, depending on the last edit.

Editing done	Message
Labeling a track or an MD	
Copying a disc title or a track title	"Name Undo?"
Erasing labeled titles	
Erasing a single track	
Erasing all tracks	"Erase Undo?"
Erasing a portion of a track	
Moving a track	"Move Undo?"
Dividing a track	"Divide Undo?"
Combining tracks	"CombineUndo?"

- 4 Press ENTER/YES again.  
"Complete !!" appears for a few seconds and the contents of the MD are restored to the condition before the edit.

To cancel Undo function  
Press MENU/NO.

## Recording your favorite CD tracks on a tape

### — CD-TAPE Synchro Recording

You can select your favorite CD tracks with the Program Play feature, then record the program on a tape using the CD Synchro Recording feature. This lets you rearrange the track order while making sure the playback time fits on each side of the tape.

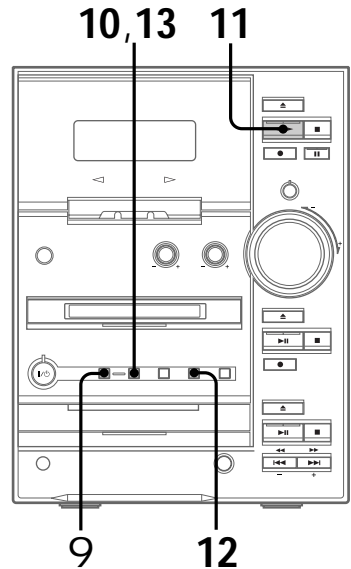



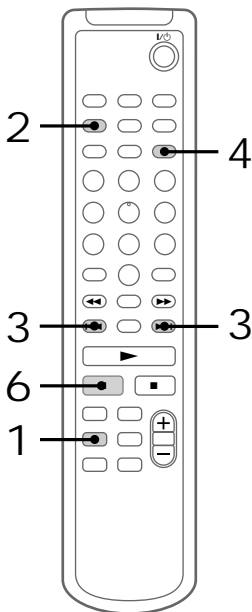

- 4 Press ENTER/YES on the remote.

The track is programmed.  
 “Step” appears, followed by the number of the track in the programmed sequence. The number of the last programmed track appears, followed by the total playing time of the program.

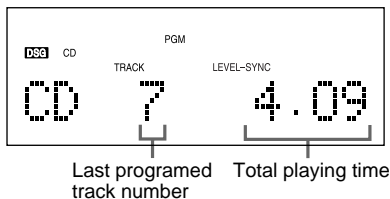

- 5 Repeat steps 3 and 4 to select the tracks to be recorded on the side where recording is to start.

- 6 Press **||** on the remote.

Recording pauses at the end of the side where recording starts. “P” appears and the total playing time display changes to “0.00.”

- 7 Repeat steps 3 and 4 to select the tracks to be recorded on the reverse side.

## Recording on a tape

- 8 Insert a blank tape.

- 9 Press SYNCHRO REC repeatedly until “CD-TAPE SYNC” appears.

*continued*

## Selecting the tracks

- 1 Press CD on the remote to switch the function to CD.
- 2 Press PLAY MODE on the remote repeatedly until “PGM” appears.
- 3 Press **◀▶** or **▶▶** on the remote repeatedly until the desired track number appears.

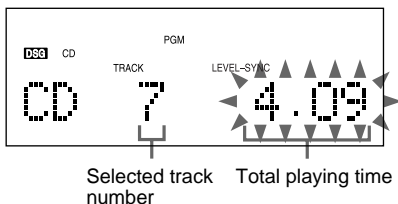

## Recording your favorite CD tracks on a tape (continued)

---

### 10 Press ENTER/START.

The tape deck stands by for recording and the CD player pauses for play.

---

### 11 Press TAPE ◀▶ to light up the right indicator to record starting from the front side.

To record from the reverse side, press TAPE ◀▶ again to light up the left indicator.

---

### 12 Press DIRECTION repeatedly until ⇄ appears to record on one side or ⇄⇄ (or ⇄⇄) to record on both sides.

If you select both sides recording and the tape reaches the end of the front side part-way through a track, the entire track is recorded again from the beginning of the reverse side. When you start recording from the reverse side, the recording stops at the end of the reverse side even though you select ⇄⇄.

---

### 13 Press ENTER/START.

CD playing and tape recording start. When the recording is completed, the CD player and the tape deck stop automatically.

---

## To stop recording

Press CD ■ or TAPE ■.

## If the tape becomes full during recording

The CD player and the tape deck stop automatically.

## To record on an MD at the same time

Insert a recordable MD and select “DUAL SYNC” in step 9 of “Recording on a tape” on page 57.

### Tip

When you want to reduce the hiss noise in low-level, high-frequency signals, press DOLBY NR after step 10 so “NR” appears in the display.

### Note

If “Cannot SYNC” appears, a disc or a tape is not loaded or you cannot record on that tape (see page 80).

# Recording an MD on a tape

You can make an analog recording of an MD on a tape with the tracks in the same sequence as the original MD.

You can also record a program of favorite tracks.

## Recording tracks in the same sequence as the original MD

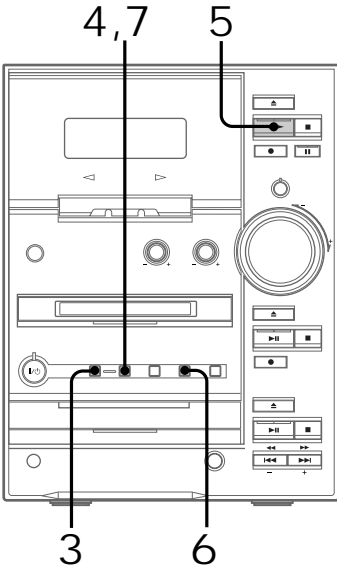

- 1 Insert a blank tape.
- 2 Insert an MD.
- 3 Press SYNCHRO REC repeatedly until "MD-TAPE SYNC" appears.

- 4 Press ENTER/START.  
The tape deck stands by for recording and the MD deck pauses for play.
- 5 Press TAPE ◀▶ to light up the right indicator to record starting from the front side.  
To record from the reverse side, press TAPE ◀▶ again to light up the left indicator.
- 6 Press DIRECTION repeatedly until ↔ appears to record on one side or ↔↔ (or ↔↔) to record on both sides.  
If you select both sides recording and the tape reaches the end of the front side part-way through a track, the entire track is recorded again from the beginning of the reverse side. When you start recording from the reverse side, the recording stops at the end of the reverse side even though you select ↔↔.
- 7 Press ENTER/START.  
MD playing and tape recording start.  
When the recording is completed, the MD deck and the tape deck stop automatically.

### To stop recording

Press MD ■ or TAPE ■.

### If the tape becomes full during recording

The MD deck and the tape deck stop automatically.

continued

## Recording an MD on a tape (continued)

### Tip

When you want to reduce the hiss noise in low-level, high-frequency signals, press DOLBY NR after step 4 so “□□” appears in the display.

### Note

If “Cannot SYNC” appears, a disc or a tape is not loaded or you cannot record on that tape (see pages 79 and 80).

## Recording your favorite MD tracks — MD-TAPE Synchro Recording

You can select your favorite MD tracks with the Program Play feature, then record the program on a tape using the MD Synchro Recording feature.

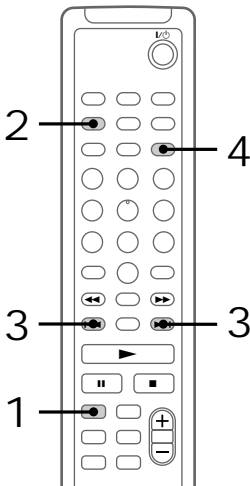

1 Press MD to switch the function to MD.

2 Press PLAY MODE repeatedly until “PGM” appears in stop mode.

3 Press ◀◀ or ▶▶ repeatedly until the desired track number appears in the display.

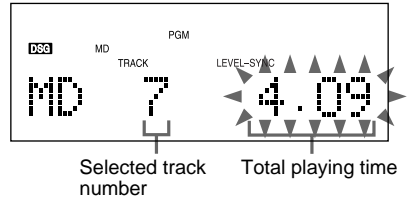

4 Press ENTER/YES.

The track is programmed. “Step” appears, followed by the number of the track in the programmed sequence. The number of the last programmed track appears, followed by the total playing time of the program.

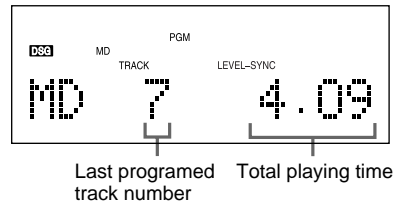

5 To program additional tracks, repeat steps 3 and 4.

6 Insert a blank tape.

7 Perform steps 3 to 7 of “Recording tracks in the same sequence as the original MD” (see page 59).

# Recording on a tape manually — Manual Recording

With manual recording, you can record just the portions you like from a CD or an MD on a tape. You can also record a radio program.

The recording level is automatically adjusted.

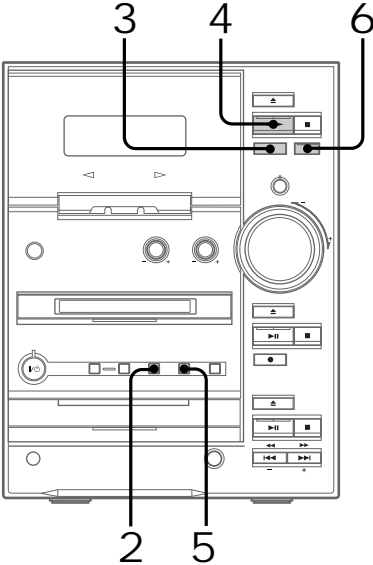

- 1 Insert a blank tape.
- 2 Press **FUNCTION** repeatedly to select the desired source (e.g., **TUNER**) to record.
  - **CD**: Recording from the CD
  - **MD**: Recording from the MD
  - **TUNER**: Recording from the radio

- 3 Press **TAPE REC** ●.  
The tape deck stands by for recording.
- 4 Press **TAPE** ◀▶ to light up the right indicator to record starting from the front side.  
To record from the reverse side, press **TAPE** ◀▶ again to light up the left indicator.
- 5 Press **DIRECTION** repeatedly until ↔ appears to record on one side or ↔↔ (or ↔↔) to record on both sides.  
When you start recording from the reverse side, the recording stops at the end of the reverse side even though you select ↔↔.
- 6 Press **TAPE** ■■.  
Recording starts.
- 7 Start playing the desired source to record.

To	Press
Stop recording	<b>TAPE</b> ■.
Pause	<b>TAPE</b> ■■.

### Tip

When you want to reduce the hiss noise in low-level, high-frequency signals, press **DOLBY NR** after step 3 so “**NR**” appears in the display.

## Adjusting the sound

Not only can you adjust the bass and treble, you can use the DSG (Dynamic Sound Generator) function to enjoy a more powerful sound.

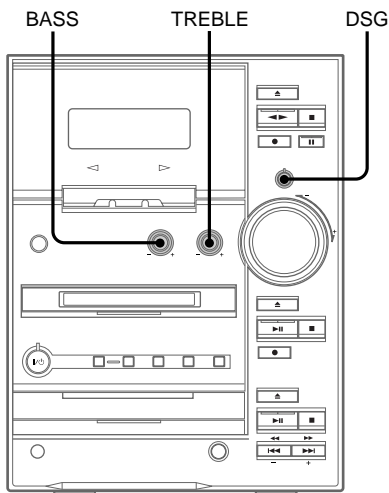

### Generating a more dynamic sound

- ➔ Press DSG.  
When DSG is on, "DSG" lights up in the display.

To cancel the DSG  
Press DSG to turn off "DSG".

### Adjusting the bass

- ➔ Turn BASS.  
You can adjust the bass in 9 steps (from MIN to MAX).

### Adjusting the treble

- ➔ Turn TREBLE.  
You can adjust the treble in 9 steps (from MIN to MAX).

To adjust the bass and treble using the remote

- 1 Press BASS/TRE to select BASS or TREBLE.  
Each time you press the button, the display changes as follows:  
BASS ↔ TREBLE
- 2 While BASS or TREBLE appears in the display, press ◀◀ or ▶▶ repeatedly until the level you want appears.

# Labeling the preset stations — Station Name

You can label each preset station with up to 12 characters (Station Name). The Station Name appears when you tune in the station.

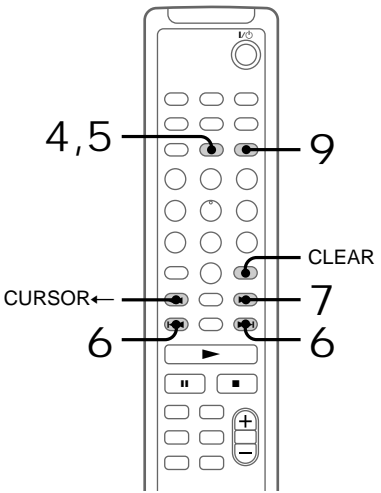
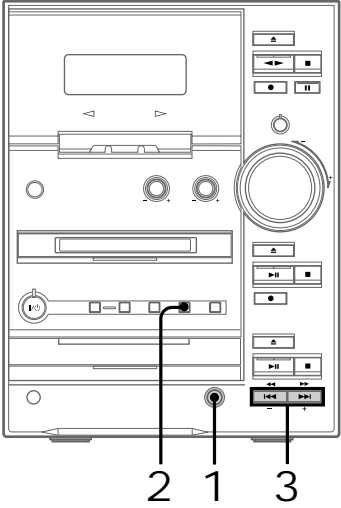

- 1 Press TUNER/BAND to select “FM” or “AM.”
- 2 Press TUNING MODE repeatedly until “PRESET” appears.
- 3 Press TUNING + or – repeatedly until the desired preset station to label appears.
- 4 Press NAME EDIT on the remote. The text input screen appears, and the cursor flashes.

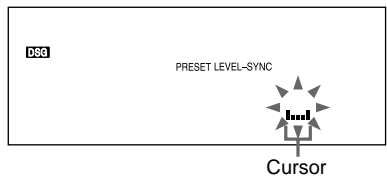

- 5 Press CHARACTER on the remote to select the desired type of character. Each time you press the button, the display changes as follows:  
 □ (Blank space)\* → A (Upper cases) → a (Lower cases) → 0 (Numbers) → ! (Symbols) → □ (Blank space)\* → ...  
 \* You cannot enter a space as the first character. For this reason, “□” (blank space) does not appear in the display when inputting the first character.

continued

## Labeling the preset stations (continued)

- 6 Press **◀◀** or **▶▶** on the remote repeatedly to select the desired character.

To enter a blank space

Press **CURSOR→** without pressing **◀◀** or **▶▶**.

To enter a symbol

You can use the following 24 symbols.

! " # \$ % & ' ( ) \* + , - . / : ; < = > ? @ \_ `

- 7 Press **CURSOR→** on the remote.

The character you selected in step 6 stops flashing and the cursor shifts to the right.

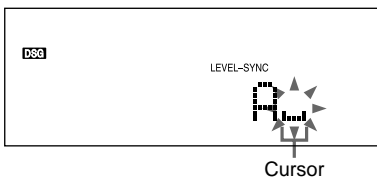

- 8 Repeat steps 5 to 7 to complete the entire title.

If you made a mistake

Press **CURSOR←** or **→** until the character you want to change flashes, then repeat steps 5 to 7.

To erase a character

Press **CLEAR** on the remote while the character is flashing. You cannot insert characters.

- 9 Press **ENTER/YES** on the remote to complete the labeling procedure.

To cancel labeling

Press **MENU/NO** on the remote.

To check the preset number and frequency

The station name appears when you tuned the labeled station.

To check the preset number and frequency, press **DISPLAY** on the remote. The preset number and frequency appear, followed by the station name.

To erase the station name

1 Perform steps 1 to 4.

2 Press **CLEAR** on the remote repeatedly to erase the name.

3 Press **ENTER/YES** on the remote.



# Using the Radio Data System (RDS)

(European model only)

## What is the Radio Data System?

Radio Data System (RDS) is a broadcasting service that allows radio stations to send additional information along with the regular program signal. RDS is available only on FM stations\*.

### Note

RDS may not work properly if the station you are tuned in is not transmitting the RDS signal properly or if the signal is weak.

\* Not all FM stations provide RDS service, nor do they provide the same types of services. If you are not familiar with the RDS system, check with your local radio stations for details on RDS services in your area.

## Receiving RDS broadcasts

➔ Simply select a station from the FM band.

When you tune in a station that provides RDS services, the station name appears in the display.

### To check the RDS information

Each time you press DISPLAY, the display changes as follows:

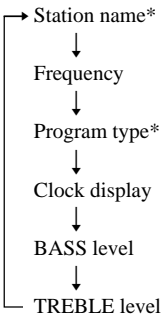

\* If the RDS broadcast is not received, the station name and program type (see page 85) may not appear in the display.

# Falling asleep to music

## — Sleep Timer

You can set the system to turn off after a certain amount of time, so that you can fall asleep to music. You can preset the time to turn off in 10 minutes increments.

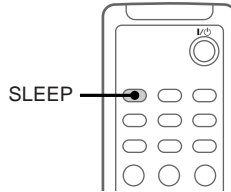

➔ Press SLEEP repeatedly to select a desired time.

Each time you press the button, the minute display (the remaining time) changes as follows:

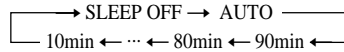

### To check the remaining time

Press SLEEP once. However, the remaining time is not displayed when “AUTO” is set.

### To change the time to turn off

Select the time you want by pressing SLEEP.

### To cancel the Sleep Timer function

Press SLEEP repeatedly until “SLEEP OFF” appears.

continued

## Falling asleep to music (continued)

When you select "AUTO"

The system automatically turns off after the CD, MD or tape finishes playing (up to 100 minutes). When the function is TUNER, the system turns off in 100 minutes.

### Tip

You can use the Sleep Timer, even if you have not set the clock.

### Note

Do not set to "AUTO" during Synchro Recording on an MD or a tape.

---

## Waking up to music

### — Daily Timer

You can wake up to music at a preset time. Make sure you have set the clock (see page 6).

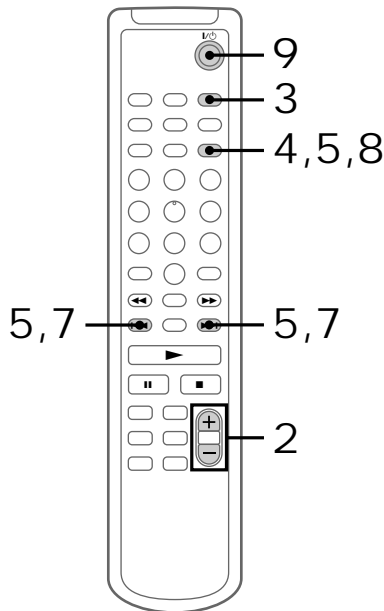

- 1 Prepare the sound source you want to play.
  - CD: Place a CD. To start from a specific track, make a program (see page 23).
  - MD: Insert an MD. To start from a specific track, make a program (see page 29).
  - Tape: Insert a tape.
  - Radio: Tune in a station (see page 7).

---

2 Press VOLUME +/- to adjust the volume.

---

3 Press CLOCK/TIMER SET.  
“SET DAILY” appears.

---

4 Press ENTER/YES.  
“ON” lights up, and the hour indication flashes.

---

5 Set the time to start playing.  
Press ◀◀ or ▶▶ repeatedly to set the hour, then press ENTER/YES.  
The minute indication flashes.

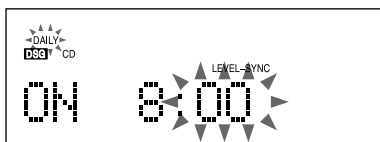

Press ◀◀ or ▶▶ repeatedly to set the minute, then press ENTER/YES.  
The hour indication flashes again.

---

6 Set the time to stop playing following the procedure in step 5.

---

7 Press ◀◀ or ▶▶ repeatedly to select the desired sound source.  
The indication changes as follows:

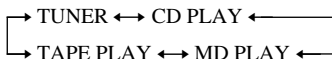

---

8 Press ENTER/YES.

The start time, the stop time, and the sound source appear in turn, then the original display returns.

---

9 Press I/⏻ to turn off the system.

---

## To change the setting

Start over from step 1.

## To check the setting/activate the timer

- 1 Press CLOCK/TIMER SELECT.
- 2 Press ◀◀ or ▶▶ repeatedly until “SEL DAILY” appears, then press ENTER/YES.

## To cancel the timer

Press CLOCK/TIMER SELECT, then press ◀◀ or ▶▶ repeatedly until “TIMER OFF” appears. Then press ENTER/YES.

## Notes

- You cannot activate Daily Timer and recording timer at the same time.
- Do not operate the system from the time the system turns on until the play starts (about 30 seconds before the preset time).
- If the system is on at the preset time, the set sound source starts playing.
- You cannot use the optional components connected to the VIDEO IN jack as the sound source for Daily Timer.

# Timer recording radio programs

To timer record, you must first preset the radio station (see page 7) and set the clock (see page 6).

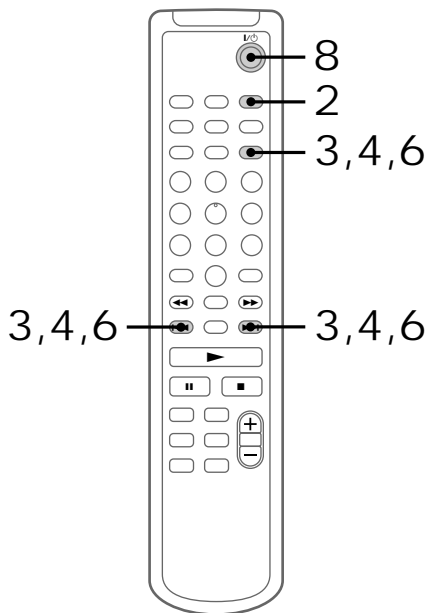

- 1 Tune in the preset radio station (see page 18).
- 2 Press CLOCK/TIMER SET.  
“SET DAILY” appears.
- 3 Press ◀◀ or ▶▶ to select either “MD REC” or “TAPE REC”, then press ENTER/YES.  
“ON” lights up, and the hour indication flashes.

- 4 Set the time to start recording.  
Press ◀◀ or ▶▶ repeatedly to set the hour, then press ENTER/YES.  
The minute indication flashes.



- Press ◀◀ or ▶▶ repeatedly to set the minute, then press ENTER/YES.  
The hour indication flashes again.
- 5 Set the time to stop recording following the procedure in step 4.
  - 6 When you record onto an MD, select STEREO or MONO by pressing ◀◀ or ▶▶, then press ENTER/YES.  
The timer recording settings appear, then the original display returns.
  - 7 Insert a recordable MD or tape.  
If you use a partially recorded MD, recording starts after the recorded tracks.  
If you use a tape, recording starts from the front side. Insert a tape with the side you want to record on facing you.
  - 8 Press I/⏻ to turn off the system.

To change the setting

Start over from step 1.

To check the setting/activate the timer

1 Press CLOCK/TIMER SELECT.

2 Press ◀◀ or ▶▶ to select either “MD REC” or “TAPE REC”, then press ENTER/YES.

To cancel the timer

Press CLOCK/TIMER SELECT and press ◀◀ or ▶▶ repeatedly until “TIMER OFF” appears. Then press ENTER/YES.

Tip

When you record from the radio, the station name (see page 63, or frequency when the station is not labeled), the start time and the stop time are automatically recorded on the MD.

Notes

- The Smart Space and Level Synchro Recording functions do not operate.
- You cannot activate Daily Timer and the recording timer at the same time.
- Do not operate the system from the time the system turns on until the recording starts (about 30 seconds before the preset time).
- When you record on a brand new MD, the first 15 seconds are not recorded.
- If the system is on about 30 seconds before the preset time, the timer-recording will not be activated.
- The volume is reduced to minimum during recording.

## Connecting optional components

### Connecting optional A/V components

To enhance your system, you can connect optional components. Refer to the operating instructions of each component.

### Connecting audio components

Connecting an MD deck and a tape deck for analog recording

You can connect an MD deck and a tape deck to the system with commercially available audio cords. Be sure to match the color-coded pins to the appropriate jacks.

To the audio input jacks on the MD deck or the tape deck

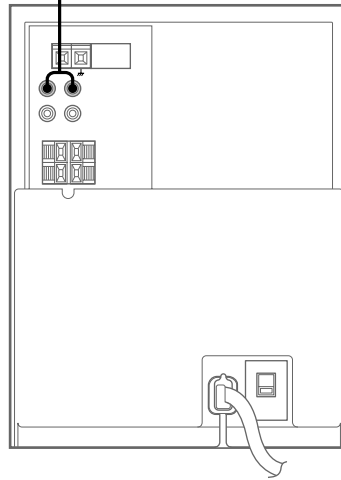

*continued*

## Connecting optional A/V components (continued)

### Connecting a VCR

You can connect a VCR to the system with a commercially available audio cord. Be sure to match the color-coded pins to the appropriate jacks. To listen to the VCR after connecting it, press FUNCTION until "VIDEO" appears.

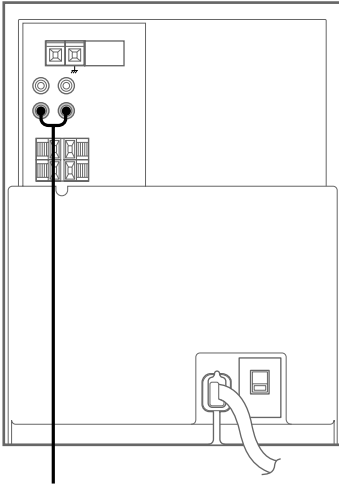

To the audio output jacks on the VCR

## Connecting headphones

Connect headphones to the PHONES jack.

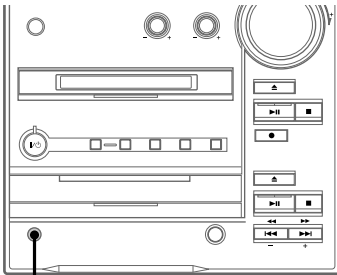

PHONES jack

## Connecting external antennas

Connect an external antenna to improve reception.

### FM antenna

Connect a commercially available FM external antenna, or you can use a TV antenna instead.

#### Jack type ①

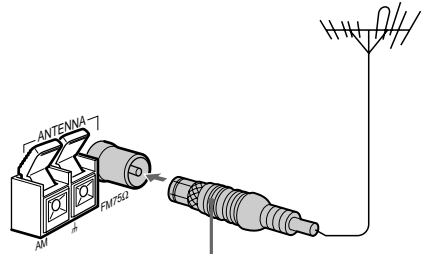

IEC standard socket connector (not supplied)

#### Jack type ②

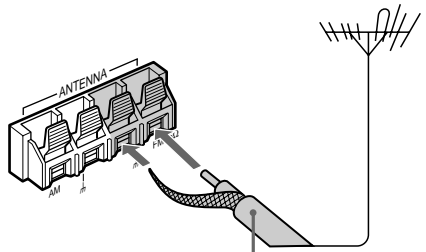

75-ohm coaxial cable (not supplied)

## AM antenna

Connect a 6- to 15- meter insulated wire to the AM antenna terminal. Leave the supplied AM loop antenna connected.

### Jack type Ⓐ

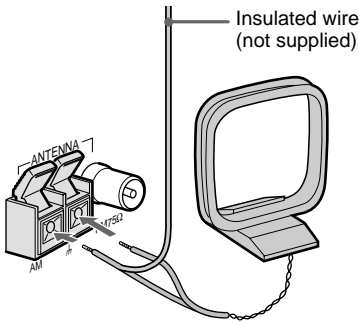

### Jack type Ⓑ

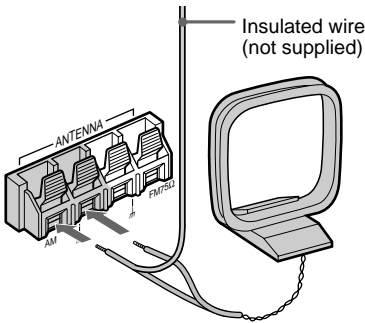

## Important

If you connect an external antenna, connect a ground wire to the *h* terminal. To prevent a gas explosion, do not connect the ground wire to a gas pipe.

## Precautions

### On safety

- The unit is not disconnected from the AC power source (mains) as long as it is connected to the wall outlet, even if the unit itself has been turned off.
- Unplug the system from the mains if it is not to be used for an extended period of time.  
To disconnect the power cord, pull it out by the plug. Never pull the cord itself.
- Should any solid object or liquid fall into the system, unplug the system and have it checked by qualified personnel before operating it any further.
- AC power cord (mains lead) must be changed only at the qualified service shop.
- When you connect the power cord to the AC power source, even if the power is off, the system begins charging for remote and timer functions. Therefore the surface of this unit become warm, this is normal.

### On placement

- Make sure the system fan is on during use.  
Place the system in a location with adequate air circulation, and do not place anything on top of the system.
- Place the system in a location with adequate ventilation to prevent heat build up.
- Do not place the system in an inclined position.
- Do not place the system in locations where it is;
  - Extremely hot or cold
  - Dusty or dirty
  - Very humid
  - Subject to vibrations
  - Subject to direct sunlight.

continued

## Precautions (continued)

### On operation

- If the system is brought directly from a cold to a warm location, or is placed in a very damp room, moisture may condense on the lens inside the CD player or the MD deck. Should this occur, the system will not operate properly. Remove the CD or MD and leave the system turned on for about an hour until the moisture evaporates.
- When you move the system, take out any discs.

If you have any questions or problems concerning your system, please consult your nearest Sony dealer.

### On the speaker system

This speaker system is not magnetically shielded and the picture on TV sets may become magnetically distorted. In such a case, turn off the power of the TV set once, and after 15 to 30 minutes turn it on again.

**If there seems to be no improvement**, locate the speaker system further away from the TV set. Also, be sure not to place objects in which magnets are attached or used near the speaker system, such as audio racks, TV stands, and toys. These may cause magnetic distortion to the picture due to their interaction with the system.

### Notes on MDs

- If you try to force the shutter open, the disc may be damaged. If the shutter opens, close it immediately without touching the disc inside.
- Affix the label supplied with the disc only to the specified label indentation. Do not affix the label around the shutter or in other locations. Note that the shape of the indentation depends on the disc.

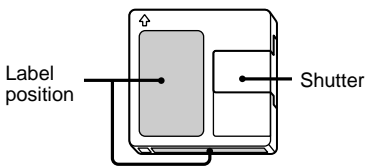

- Wipe the disc cartridge with a dry cloth to remove dirt.
- Do not expose the MD to direct sunlight or heat sources such as hot air ducts, nor leave it in a car parked in direct sunlight.

### Notes on CDs

- Before playing, clean the CD with a cleaning cloth. Wipe the CD from the center out.
- Do not use a CD with tape, seals, or paste on it as this may damage the player.
- Do not use solvents such as benzine, thinner, commercially available cleaners, or antistatic spray intended for vinyl LPs.
- Do not expose the CD to direct sunlight or heat sources such as hot air ducts, nor leave it in a car parked in direct sunlight.

### Cleaning the cabinet

Use a soft cloth slightly moistened with mild detergent solution.

### Before placing a cassette in the tape deck

Take up any slack in the tape. Otherwise, the tape may get entangled in the parts of the tape deck and become damaged.

### When using a tape longer than 90 minutes

The tape is very elastic. Do not change the tape operations such as play, stop, and fast-winding frequently. The tape may get entangled in the tape deck.

### To save a tape permanently

To prevent a tape from being accidentally recorded over, break off the cassette tab from side A or B as illustrated.

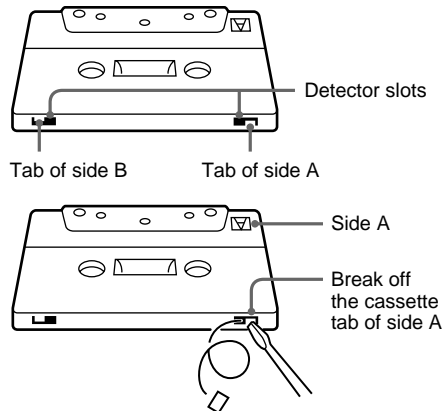



If you later want to reuse the tape for recording, cover the broken tab with adhesive tape. However, be careful not to cover the detector slots which allow the tape deck to automatically detect the type of tape.

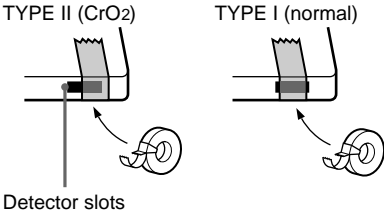

## Cleaning the tape heads

Clean the tape heads after every 10 hours of use.

When the tape heads become dirty;

- the sound is distorted
- there is a decrease in sound level
- the sound drops out
- the tape does not erase completely
- the tape does not record.

Be sure to clean the tape heads before you start an important recording or after playing an old tape.

Use a separately sold dry-type or wet-type cleaning cassette. For details, refer to the instructions of the cleaning cassette.

## Demagnetising the tape heads

Demagnetise the tape heads and the metal parts that has contact with the tape after every 20 to 30 hours of use with a separately sold demagnetising cassette. For details, refer to the instructions of the demagnetising cassette.

# System limitations of MDs

The recording system in your MD deck has the limitations described below.

Note, however, that these limitations are due to the inherent nature of the MD recording system itself, not to mechanical causes.

“Disc Full!!!” appears before the MD has reached the maximum recording time

When 255 tracks have been recorded on the MD, “Disc Full!!!” appears regardless of the total recorded time. More than 255 tracks cannot be recorded on the MD. To continue recording, erase unnecessary tracks or use another recordable MD.

“Disc Full!!!” appears before the maximum number of tracks (255) is reached

Fluctuations in emphasis within tracks are sometimes interpreted as track intervals, increasing the track count and causing “Disc Full!!!” to appear.

The remaining recording time does not increase even after erasing numerous short tracks

Tracks shorter than 12 seconds are not counted, so erasing them may not increase the recording time.

Some tracks cannot be combined with others

Track combination may become impossible when tracks are shorter than 8 seconds. Track combination of edited tracks may also become impossible.

The total recorded time and the remaining time on the MD do not add up to the maximum recording time

Recording is done in minimum units of 2 seconds each, no matter how short the material. The recorded contents may be shorter than the maximum recording capacity. Disc space may also be reduced by scratches.

continued

## System limitations of MDs (continued)

The sound may drop-out while searching the edited tracks

Tracks created through editing may exhibit sound dropout during searching because high-speed playback requires time to search for the position on the disc when the tracks are not in order.

Track numbers cannot be marked

When "LEVEL-SYNC" (page 37) lights up in the display window during analog recording, the track numbers may not be marked at the beginning of the track:

- if the input signal is below a certain fixed level for less than two seconds between tracks.
- if the input signal is below a certain fixed level for more than two seconds in the middle of the track.

## Guide to the Serial Copy Management System

Digital audio components, such as CDs, MDs, and DATs let you copy music easily with high quality by processing music as a digital signal.

To protect the copyrighted music programs, this system uses the Serial Copy Management System that allows you to make only a single copy of a digitally recorded source through digital-to-digital connections.

**You can make only a first generation copy\* through a digital-to-digital connection.**

That is:

- 1 You can make a copy of a commercially available digital sound program (for example, a CD or MD), but you cannot make a second copy from the first-generation copy.
- 2 You can make a copy of a digital signal from a digitally recorded analog sound program (for example, an analog record or a music cassette tape) or from a digital satellite broadcast program, but you cannot make a second copy.

\* A first-generation copy means a digital recording of a digital signal made on digital audio equipment. For example, if you record from this system's CD player to the MD deck, you make a first-generation copy.

---

## Troubleshooting

If you have any problem using this system, use the following checklist.

First, check that the power cord is connected firmly and that the speakers are connected correctly and firmly.

Should any problem persist, consult your nearest Sony dealer.

---

### General

---

**There is no sound.**

- Turn VOLUME clockwise.
- Make sure the headphones are not connected.
- Check the speaker connections (see page 4).

---

**Sound comes from one channel, or unbalanced left and right volume.**

- Connect the speaker cords properly (see page 4).
- Place the speakers as symmetrically as possible.
- Connect only one of the supplied speakers to each set of speaker terminals.
- Connect the supplied speakers.

---

**There is severe hum or noise.**

- Move the system away from the source of noise.
- Connect the system to a different wall outlet.
- Install a noise filter (commercially available) to the power line.

---

**"0:00" (for European model) or "12:00 AM" (for other models) flashes in the display.**

- Set the clock and timer again (see pages 6, 66 and 68).

---

**The timer cannot be set.**

- Set the clock again (see page 6).

---

**The timer does not function.**

- Press CLOCK/TIMER SELECT to set the timer and light up “DAILY” or “REC” in the display (see pages 67 and 69).
- Check the set contents and set the correct time (see pages 6, 66 and 68).
- Cancel the Sleep Timer function (see page 65).

---

**The remote does not function.**

- Remove the obstacle.
- Move the remote closer to the system.
- Point the remote at the system’s sensor.
- Replace the batteries (size AA/R6).
- Locate the system away from the fluorescent light.

---

**“PROTECT” and “PUSH POWER” appear alternately.**

- Press I/⏻ (power) to turn off the system. Turn on the system again after a while.

---

## CD Player

---

**The CD tray does not close.**

- Place the CD correctly in the center of the tray.
- Always close the tray by pressing CD ▲. Trying to push the tray closed with your fingers may cause problems with the CD player.

---

**The CD does not eject.**

- Consult your nearest Sony dealer.

---

**Play does not start.**

- Open the CD tray and check whether a CD is loaded.
- Wipe the CD clean (see page 72).
- Replace the CD.
- The CD is placed with the label side down. Place the CD correctly in the center of the tray.
- Remove the CD and wipe away the moisture on the CD, then leave the system turned on for a few hours until the moisture evaporates.
- Press CD ▶|| to start play.

---

**The sound skips.**

- Wipe the CD clean (see page 72).
  - Replace the CD.
  - Try moving the system to a place without vibration (e.g., on top of a stable stand).
  - Try moving the speakers away from the system, or placing them on separate stands.
- When you listen to a track with bass sounds at high volume, the speaker vibration may cause the sound to skip.

---

**Play does not start from the first track.**

- Press PLAY MODE repeatedly until “PGM” or “SHUFFLE” disappears to return to normal play.

---

**“—OVER—” appears.**

- Press and hold ◀◀ or press ◀◀ to return to the desired playing position.

---

*continued*

## MD Deck

---

### An MD cannot be inserted.

- Insert the MD with the arrow side up and the arrow pointing toward the deck.

---

### The controls do not work.

- Replace the MD with a new one.
- Retry the operations after “TOC” or “STANDBY” turns off.

---

### Play does not start.

- Replace the MD.
- Insert the MD and leave the system turned on for a few hours until the moisture evaporates.
- Press MD ►|| to start play.

---

### The sound skips.

- Replace the MD.
- Try moving the system to a place without vibration (e.g., on top of a stable stand).
- Try moving the speakers away from the system, or placing them on separate stands.  
When you listen to a track with bass sounds at high volume, the speaker vibration may cause the sound to skip.
- Insert the disc and wait for 10 to 20 minutes with the system turned on.

---

### Play does not start from the first track.

- Press PLAY MODE repeatedly until “PGM” or “SHUFFLE” disappears to return to normal play.

---

### “—OVER—” appears.

- Press and hold ◀◀ or press ◀◀ to return to the desired playing position.

---

### “OVER” lights up during recording.

- Adjust the recording level lower (see page 41).

---

### Recording or editing was done, but the TOC is not updated.

- MD recording and editing contents are recorded to the MD when the MD is removed, so make sure you remove the MD after recording or editing (see pages 32 and 44).

---

### Recording is not possible.

- Remove the MD and slide the tab to close the slot (see page 32).
- Connect the optional A/V component properly (see page 69).
- Switch to another sound source.
- Replace the MD with a recordable MD, or use Erase Function to erase unnecessary tracks (see page 47).
- Start recording over from the beginning.

---

### The sound from an MD you recorded is too low (or too high).

- Readjust the recording level (see page 41).
-

## Tape Deck

---

### The tape does not record.

- No cassette is inserted. Insert a cassette.
  - The tab has been removed from the cassette. Cover the broken tab with adhesive tape (see page 73).
  - The tape has wound to the end.
- 

### The tape does not record or play, or there is a decrease in sound level.

- The heads are dirty. Clean them.
  - The record/playback heads are magnetised. Demagnetise them (see page 73).
- 

### The tape does not erase completely.

- The record/playback heads are magnetised. Demagnetise them (see page 73).
- 

### There is excessive wow or flutter, or the sound drops out.

- The capstans or pinch rollers in the tape deck are dirty. Clean them using a cleaning cassette (see page 73).
- 

### Noise increases or the high frequencies are erased.

- The record/playback heads are magnetised. Demagnetise them (see page 73).
- 

## Optional components

---

### There is no sound.

- Refer to General item “There is no sound” on page 74 and check the condition of the system.
  - Connect the component properly (see page 69) while checking:
    - if the cords are connected properly.
    - if the cord plugs are firmly inserted all the way.
  - Turn on the connected component.
  - Refer to the operating instructions included with the connected component and start playing.
- 

### The sound is distorted.

- Set the volume of the connected component lower.
- 

## Tuner

---

### There is severe hum or noise (“TUNED” or “STEREO” flashes).

- Set the proper band and frequency (see page 7).
- Connect the antenna properly (see page 4).
- Find a place and an orientation that provide good reception, then set up the antenna again. If you cannot obtain good reception, we recommend you connect a commercially available external antenna.
- The supplied FM lead antenna receives signals along its entire length, so make sure you extend it fully.
- Locate the antennas as far away from the speaker cords as possible.
- Consult your nearest Sony dealer if the supplied AM antenna wire has come off the plastic stand.
- Try turning off surrounding electrical equipment.

continued

---

**A stereo FM program cannot be received in stereo.**

- Press STEREO/MONO until “STEREO” appears in the display.
- See “There is severe hum or noise (“TUNED” or “STEREO” flashes)”, and check the antenna condition.

---

**Cyclical static noise is heard while recording on an MD.**

- Adjust the antenna orientation and position until the noise stops.

---

If the system still does not operate properly after performing the above measures, reset the system as follows:

Press the RESET switch on the bottom of the system using a ball-point pen, etc.

The system is reset to the factory settings. All the settings you made such as the preset stations, clock, timer and CD disc titles are cleared. You should set them again.

---

## Self-diagnosis display

This system has a Self-diagnosis display function to let you know if there is a system malfunction. The display shows a code made up of three letters and a message alternately to show you the problem. To solve the problem refer to the following list. If any problem persists, consult your nearest Sony dealer.

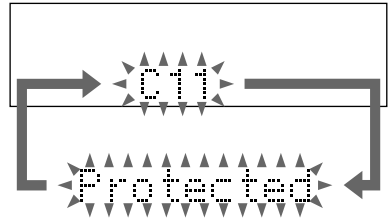

---

**C11/Protected**

The MD is protected against erasure.

- Remove the MD and slide the tab to close the slot (see page 32).

---

**C12/Cannot Copy**

You tried to record a CD or MD with a format that the system does not support, such as a CD-ROM.

- Remove the disc and turn off the system once, then turn it on again.

---

**C13/REC Error**

Recording could not be performed properly.

- Move the system to a stable place, and start recording over from the beginning.

The MD is dirty or scratched, or the MD does not meet the standards.

- Replace the MD and start recording over from the beginning.

---

**C13/Read Error**

The MD deck cannot read the disc information properly.

→Remove the MD once, then insert it again.

---

**C14/Toc Error**

The MD deck cannot read the disc information properly.

→Replace the MD.

→Erase all the recorded contents of the MD using All Erase Function (see page 48).

---

**C41/Cannot Copy**

The sound source is a copy of commercially available music software, or you tried to record a CD-R (Recordable CD).

→The Serial Copy Management System prevents making a digital copy (see page 74). You cannot record a CD-R.

---

## Messages

One of the following messages may appear or flash in the display during operation.

---

**MD****Auto Cut**

The MD deck is pausing the recording because silence continued for 30 seconds or more during digital recording.

---

**Blank Disc**

The inserted recordable MD is new, or all tracks on the MD have been erased.

---

**Cannot Edit**

- A pre-mastered MD is in the deck.
  - You tried to edit in Program or Shuffle Play mode.
- 

**Cannot REC**

- A pre-mastered MD is in the deck.
  - The function is switched to MD.
- 

---

**Cannot SYNC**

- There is no disc in the MD deck, or the MD is protected against erasure.
  - There is no time remaining on the MD.
- 

**Complete !!**

The editing operation of MDs is completed.

---

**Disc Full!!**

There is no time remaining on the MD.

---

**Eject**

The MD deck is ejecting the MD.

---

**Impossible**

- You tried to make an impossible editing operation.
  - You cannot combine the tracks due to the system limitations of MDs.
- 

**Name Full**

There is no more space to store track or disc titles.

---

**No Disc**

There is no disc in the MD deck.

---

**No Name**

You tried to show the title of a non-labeled disc or track.

---

**—OVER—**

You have reached the end of the MD while press and hold ►► during playing pause.

---

**Push STOP!**

You pressed PLAY MODE during play.

---

**—Rehearsal—**

The MD is playing the specified dividing point for confirmation during the Divide function.

---

**Smart Space**

The signal was input again after silence continued for 3 or more but less than 30 seconds during digital recording.

---

*continued*

## *Self-diagnosis display (continued)*

---

### **Standby (flashing)**

The timer-recorded material has disappeared over time and is not available for saving to disc, or Program Play could not be activated since the program has disappeared over time.

---

### **Text Protect**

There is CD TEXT information which cannot be recorded on the MD.

---

### **TOC Reading**

The MD deck is reading the TOC information of the MD.

---

### **TOC Writing**

The MD deck is writing the information of recorded or edited contents.

---

### **Track End**

You have reached the end of the track while adjusting the dividing point during the Divide Function.

---

## TUNER

---

### **Cannot Edit**

You tried to label or erase a non-preset station.

---

## CD

---

### **Cannot Edit**

You tried to label a CD TEXT disc.

---

### **Name Full**

There are already 50 disc titles stored in the system.

---

### **—OVER—**

You have reached the end of the CD while keeping pressing ►► during play or pause.

---

## TAPE

---

### **Cannot SYNC**

There is no tape in the tape deck, or the tab has been removed from the cassette.

---

### **No TAB**

You cannot record the tape because the tab has been removed from the cassette.

---

### **NO TAPE**

There is no tape in the tape deck.

---



# Specifications

Main Unit (HCD-CP33)

Amplifier section

For the U.S. model

## AUDIO POWER SPECIFICATIONS POWER OUTPUT AND TOTAL HARMONIC DISTORTION:

With 6-ohm loads, both channels driven, from 70 – 20,000 Hz; rated 18 watts per channel minimum RMS power, with no more than 0.9% total harmonic distortion from 250 milliwatts to rated output.

### North American model:

Continuous RMS power output (reference):  
35 + 35 watts  
(6 ohms at 1 kHz, 10% THD)

Total harmonic distortion: less than 0.07%  
(6 ohms at 1 kHz, 18 W)

### European model:

DIN power output (Rated): 30 + 30 watts  
(6 ohms at 1 kHz, DIN, 230 V)

Continuous RMS power output (Reference):  
35 + 35 watts  
(6 ohms at 1 kHz,  
10% THD, 230 V)

Music power output (Reference):  
85 + 85 watts

### Other models:

The following measured at 230 V AC, 60 Hz  
DIN power output (rated): 28 + 28 watts  
(6 ohms at 1 kHz, DIN)

Continuous RMS power output (reference):  
30 + 30 watts  
(6 ohms at 1 kHz, 10% THD)

The following measured at 220 V AC, 60 Hz  
DIN power output (rated): 24 + 24 watts  
(6 ohms at 1 kHz, DIN)

Continuous RMS power output (reference):  
25 + 25 watts  
(6 ohms at 1 kHz, 10% THD)

### Inputs

VIDEO IN (phono jacks): voltage 250 mV, impedance 47 kilohms

### Outputs

LINE OUT (phono jack): voltage 250 mV, impedance 1 kilohm

PHONES (stereo minijack):  
accepts headphones of 8 ohms or more.

SPEAKER:  
accepts impedance of 6 to 16 ohms.

## CD player section

System Compact disc and digital audio system

Laser Semiconductor laser ( $\lambda=780$  nm)  
Emission duration: continuous

Laser output Max. 44.6  $\mu$ W\*  
\*This output is the value measured at a distance of 200 mm from the objective lens surface on the Optical Pick-up Block with 7 mm aperture.

Frequency response 2 Hz – 20 kHz

## MD deck section

System MiniDisc digital audio system

Laser Semiconductor laser ( $\lambda=780$  nm)  
Emission duration: continuous

Laser output Max. 44.6  $\mu$ W\*  
\*This output is the value measured at a distance of 200 mm from the objective lens surface on the Optical Pick-up Block with 7 mm aperture.

Sampling frequency 44.1 kHz

Frequency response 5 Hz – 20 kHz

## Tape deck section

Recording system 4-track 2-channel stereo (DOLBY NR OFF)

Frequency response 40 – 13,000 Hz ( $\pm 3$  dB), using Sony TYPE I cassettes  
40 – 14,000 Hz ( $\pm 3$  dB), using Sony TYPE II cassettes  
Wow and flutter  $\pm 0.13\%$  W. Peak (IEC)  
0.07% W. RMS (NAB)  
 $\pm 0.2\%$  W. Peak (DIN)

continued

## Specifications (continued)

### Tuner section

FM stereo, FM/AM superheterodyne tuner

#### FM tuner section

Tuning range

North American model: 87.5 – 108.0 MHz  
(100 kHz step)

Tourist model: 76.0 – 108.0 MHz  
(50 kHz step)

Other models: 87.5 – 108.0 MHz  
(50 kHz step)

Antenna FM lead antenna

Antenna terminals 75 ohms unbalanced

Intermediate frequency 10.7 MHz

#### AM tuner section

Tuning range

Pan-American model: 530 – 1,710 kHz  
(with the interval set at 10 kHz)

531 – 1,710 kHz  
(with the interval set at 9 kHz)

European model: 531 – 1,602 kHz  
(with the interval set at 9 kHz)

Other models: 531 – 1,602 kHz  
(with the interval set at 9 kHz)

530 – 1,710 kHz  
(with the interval set at 10 kHz)

Antenna AM loop antenna

External antenna terminals

Intermediate frequency 450 kHz

### Speaker (SS-CCP33)

Speaker system 2-way, bass-reflex type

Speaker units

Woofer: 12 cm dia., cone type

Tweeter: 2.5 cm dia., balanced drive type

Nominal impedance 6 ohms

Dimensions (w/h/d) Approx. 150 × 252 × 255 mm

Mass Approx. 2.6 kg net per speaker

## General

Power requirements

North American model: 120 V AC, 60 Hz

European model: 230 V AC, 50/60 Hz

Australian and Thai models:

220 – 240 V AC, 50/60 Hz

Other models: 110 – 120 V or 220 – 240 V AC,  
50/60 Hz

Adjustable with voltage selector

Power consumption 75 watts

Dimensions (w/h/d) incl. projecting parts and controls

Amplifier/Tuner/Tape/MD/CD section:

Approx. 190 × 252 × 345 mm

Mass

Amplifier/Tuner/Tape/MD/CD section:

Approx. 7.5 kg

Supplied accessories

Remote (1)

Size AA (R6) batteries (2)

AM loop antenna (1)

FM lead antenna (1)

Design and specifications are subject to change without notice.

# Parts descriptions for the remote

You can use the supplied remote to control the system.

## Note

You cannot perform the following operations with the remote;

- TUNING MODE setting for the tuner
- STEREO/MONO setting for the tuner
- Removing discs
- Recording on the MD or the tape
- One Touch Play

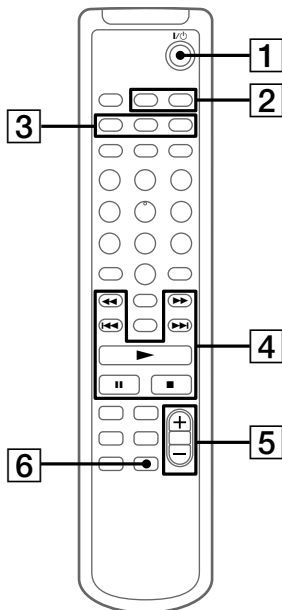

### 1 I/O (power) switch

### 2 CLOCK/TIMER SELECT button

Press to check timer settings, or to set the timer on/off (pages 67 and 69).

### CLOCK/TIMER SET button

Press to set the clock and timer functions (pages 6, 67 and 68).

### 3 PLAY MODE button

Press to select normal play, Shuffle Play or Program Play (pages 23, 28, 29, 33 and 60).

### REPEAT button

Press to play a track or all the tracks repeatedly (pages 22 and 28).

### BASS/TRE button

Press to adjust the bass and treble (page 62).

### 4 CURSOR ←/→, ◀▶ buttons

Press to label a CD, MD and preset station, or to set the clock (pages 6, 27, 46 and 64).

The ◀▶ buttons locate a desired point in a track during MD playing pause, during CD play or pause, or fast-forward or rewind a tape.

### ◀▶ (AMS: Automatic Music Sensor) buttons

### ▶ (play) button

### || (pause) button

### ■ (stop) button

### 5 VOLUME +/- buttons

Press to adjust the volume.

### 6 DSG button

Press to generate a more dynamic sound (page 62).

continued

Parts descriptions for the remote (continued)

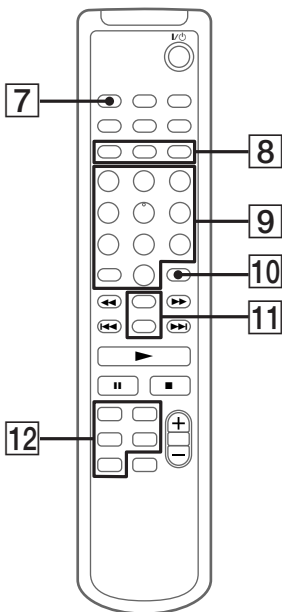

**7 SLEEP button**

Press to set Sleep Timer (page 65).

**8 MENU/NO button**

Press to preset stations, to enter the settings in “Edit Menu” or “Setup Menu”, or to cancel editing.

**NAME EDIT/CHARACTER button**

Press to display the text input screen and to select the type of characters to be input (pages 26, 45 and 63).

**ENTER/YES button**

Press to set the clock, Program Play and to complete presetting stations or editing.

**9 Number buttons**

Press to select track numbers of a CD, MD, or preset station.

**10 CLEAR button**

Press to cancel the selection (pages 24, 27, 30, 46 and 64).

**11 SCROLL button**

Press to display the disc title or track title scrolling (pages 27, 31 and 46).

**DISPLAY button**

Press to show the various information (pages 24, 25, 29, 30 and 64).

**12 The sound source buttons**

**MD button**

**CD button**

**FUNCTION button**

Press to switch the sound source.

Each time you press this button, the sound source changes as follows:



**BAND, TUNER button**

Press to select the tuner for the sound source, or to select the FM or AM band.

**TAPE button**

---

# List of program types (PTY)

---

## **NEWS**

News programs.

---

## **AFFAIRS**

Topical programs that expand on current news.

---

## **INFO**

Programs about consumer affairs, medical advice.

---

## **SPORT**

Sports programs.

---

## **EDUCATE**

Educational programs, such as “how-to” programs and advice.

---

## **DRAMA**

Radio plays and serials.

---

## **CULTURE**

Programs about national or regional culture, language, and social concerns.

---

## **SCIENCE**

Programs about the natural sciences.

---

## **VARIED**

Programs containing celebrity interviews, panel games, and comedy.

---

## **POPM**

Popular music programs.

---

## **ROCKM**

Rock music programs.

---

## **EASYM**

Easy listening (middle of the road music).

---

## **LIGHTM**

Classical music, such as instrumental, vocal, and choral works.

---

## **CLASSICS**

Performances of major orchestras, chamber music, opera, etc.

---

## **OTHERM**

Music, such as rhythm and blues and reggae.

---

---

## **WEATHER**

Weather information.

---

## **FINANCE**

Stock market reports and trading, etc.

---

## **CHILDREN**

Programs for young.

---

## **SOCIAL**

Programs about people and the things that affect them.

---

## **RELIGION**

Programs of religious contents.

---

## **PHONEIN**

Programs where members of the public express their views by phone or in a public forum.

---

## **TRAVEL**

Programs about travel. Not for announcements that are located TP/TA.

---

## **LEISURE**

Programs on recreational activities such as gardening, fishing, cooking, etc.

---

## **JAZZ**

Jazz programs.

---

## **COUNTRY**

Country music programs.

---

## **NATIONM**

Programs featuring the popular music of the country or region.

---

## **OLDIES**

Programs featuring oldies music.

---

## **FOLKM**

Folk Music Programs.

---

## **DOCUMENT**

Investigative features.

---

## **TEST**

Test signal for emergency broadcasts.

---

## **ALARM**

Emergency broadcasts.

---

## **NONE**

Any programming not defined above.

---

# Index

## A

- A-B Erase Function 49
- Adjusting
  - the bass 62
  - the operating voltage 5
  - the recording level 41
  - the sound 62
  - the treble 62
  - the volume 9, 14, 16, 18
- Antennas 4
- After
  - editing an MD 44
  - recording on an MD 32
- All Erase Function 48
- Analog recording 31
- Auto Cut 39
- Automatic Source Selection 10, 15, 16, 19
- Automatic tuning 19

## B

- Batteries 5
- Before
  - editing an MD 44
  - recording on an MD 31

## C

- CD-MD Synchro Recording 32
- CD-TAPE Synchro Recording 56
- CD TEXT information 25, 34
- Clock setting 6
- Combine Function 53
- Connecting. See Hooking up

## D

- Daily Timer 66
- Digital recording 31
- Disc Memo 26
- Display 25, 30
- Divide Function 52
- Dynamic Sound Generator 62

## E, F, G

- Erase Function 47
- Erasing
  - a portion of a track 49
  - a single track 47
  - a track number 53
  - all tracks on an MD 48
  - titles on an MD 47

## H, I, J, K

- Hooking up
  - optional components 69
  - the antennas 4
  - the power cord 5
  - the speakers 4

## L

- Labeling
  - a CD 26
  - a preset station 63
  - an MD 45
- Level Synchro Recording 37
- Listening to the radio 18

## M

- Manual tuning 19
- Messages 79
- MD-TAPE Synchro recording 60
- Move Function 51

## N

- Name Function 45
- Normal Play 9, 14, 15

## O

- One Touch Play 10, 15, 16, 19
- Optional components 69

## P, Q

- Playing
  - a CD 9, 22
  - a tape 15
  - an MD 14, 28
  - tracks in random order (Shuffle Play) 23, 28
  - tracks in the desired order (Program Play) 23, 29
  - tracks repeatedly (Repeat Play) 22, 28
- Preset Tuning 18
- Presetting radio stations 7
- Program Play 23, 29
- Program types 85
- Protecting recordings 32, 72

## R

- Radio Data System 65
- Radio stations
  - presetting 7
  - tuning in 18
- Recording
  - a CD 10, 32, 56
  - a radio program 19, 35, 68
  - an MD 59
  - manual recording 34, 61
  - monaural recording 42
  - on a tape 12, 21, 56
  - on an MD 10, 19, 32
  - timer recording 68
- Repeat Play 22, 28
- Resetting the system 78

## S

- Saving recordings 32, 72
- Self-diagnosis display 78
- Serial copy management system  
74
- Setting the time 6
- Shuffle Play 23, 28
- Sleep Timer 65
- Smart Space 39
- Sound adjustment 62
- Speakers 4
- Station Name 63
- System limitations 73

## T

- TAPE-MD Synchro recording  
16
- Time Machine Recording 35
- Timer
  - falling asleep to music 65
  - timer recording 68
  - waking up to music 66
- Track Erase Function 47
- Track marking 37, 38
- Troubleshooting 74
- Tuning interval 8

## U, V, W, X, Y, Z

- Undo Function 55

