

Stereo Cassette Deck

Operating Instructions

TC-WA9ES

WARNING

To prevent fire or shock hazard, do not expose the unit to rain or moisture.

For the customers in the United States

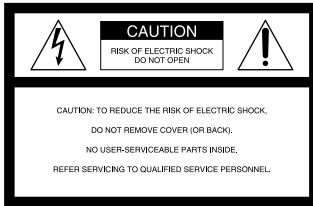

This symbol is intended to alert the user to the presence of uninsulated “dangerous voltage” within the product’s enclosure that may be of sufficient magnitude to constitute a risk of electric shock to persons.



This symbol is intended to alert the user to the presence of important operating and maintenance (servicing) instructions in the literature accompanying the appliance.

Owner’s Record

The model and serial numbers are located on the rear of the unit. Record the serial number in the space provided below. Refer to them whenever you call upon your Sony dealer regarding this product.

Model No. TC-WA9ES

Serial No. _____

INFORMATION

This equipment has been tested and found to comply with the limits for a Class B digital device, pursuant to Part 15 of the FCC Rules.

These limits are designed to provide reasonable protection against harmful interference in a residential installation. This equipment generates, uses, and can radiate radio frequency energy and, if not installed and used in accordance with the instructions, may cause harmful interference to radio communications. However, there is no guarantee that interference will not occur in a particular installation. If this equipment does cause harmful interference to radio or television reception, which can be determined by turning the equipment off and on, the user is encouraged to try to correct the interference by one or more of the following measures:

- Reorient or relocate the receiving antenna.
- Increase the separation between the equipment and receiver.
- Connect the equipment into an outlet on a circuit different from that to which the receiver is connected.
- Consult the dealer or an experienced radio/TV technician for help.

CAUTION

You are cautioned that any changes or modifications not expressly approved in this manual could void your authority to operate this equipment.

For the customers in Canada

CAUTION

TO PREVENT ELECTRIC SHOCK, DO NOT USE THIS POLARIZED AC PLUG WITH AN EXTENSION CORD, RECEPTACLE OR OTHER OUTLET UNLESS THE BLADES CAN BE FULLY INSERTED TO PREVENT BLADE EXPOSURE.

Welcome!

Thank you for purchasing the Sony Stereo Cassette Deck. Before operating the unit, please read this manual thoroughly and retain it for future reference.

About This Manual

This manual covers models for the U.S.A., Canada, and other countries. Please note the following differences in design and function according to the country of purchase.

Models for the U.S.A. and Canada

- Remote is not supplied.
- Voltage selector is not equipped.
- CONTROL S connector is equipped.

Models for other countries

- Remote is supplied.
- Voltage selector is equipped (except for Australian model).
- CONTROL S connector is not equipped.

Any difference in operation is clearly indicated in the text, for example, “not supplied with the U.S.A. and Canadian models.”

Conventions

- Instructions in this manual describe the controls on the cassette deck. You can also use the controls on the remote (not supplied with the U.S.A. and Canadian models) if they have the same or similar names as those on the deck.
- The following icons are used in this manual:



Indicates a task that requires use of the remote.



Indicates useful information or tips that make a task easier.

TABLE OF CONTENTS

Recording on a Tape 4

Playing a Tape 6

Getting Started

Unpacking 7

Hooking Up the System 7

Advanced Playback Operations

Locating a Track (Multi-AMS/Auto Play/Memory Play/Blank Skip) 9

Creating Your Own Program (RMS Play) 10

Playing a Tape Using a Timer 11

Advanced Recording Operations

Adjusting Bias and Recording Level Calibration Automatically 12

Dubbing a Tape 13

Recording on Both Decks in Succession (Relay Recording) 14

Recording the Same Source on Both Decks (Simultaneous Recording) 15

Recording Your Own Program (RMS Dubbing) 15

Inserting a Blank Space During Recording (Record Muting) 16

Synchro-Recording With a CD Player 16

Recording Using a Timer 17

Additional Information

Precautions 18

Notes on Cassette Tapes 18

Cleaning 19

Troubleshooting 20

Specifications 21

Glossary 22

Index 22

Recording on a Tape

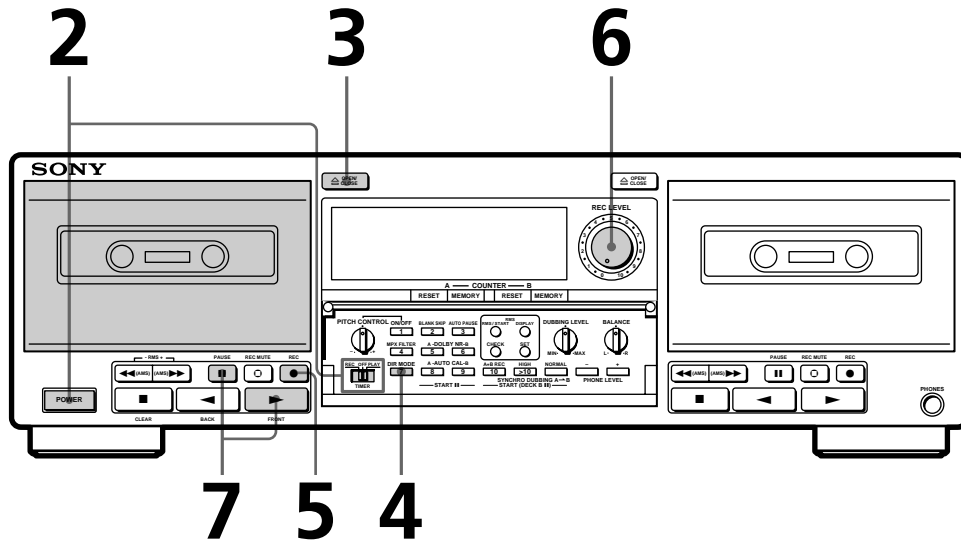

- See page 7 for hookup information.
- You can record on either deck.
- Refer to "Dubbing a Tape" (page 13) to make a copy of the tape.

1 Turn on the amplifier and play the program source you want to record.

2 Set TIMER to OFF and press POWER.

3 Press OPEN/CLOSE and insert a cassette, then press the button again to close the cassette holder.

With the side you want to record facing you.

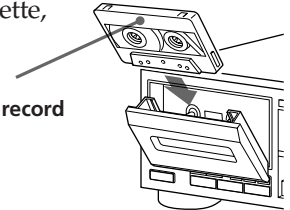

4 Select the direction mode.

To record on Press DIR MODE repeatedly to select

Only one side

Both sides*

Both decks in succession RELAY (see page 14)

* Recording stops when the tape reaches the end of reverse side.

5 Press REC . "▷", "||", and "REC" for the deck you're using light up. "▷" indicates the side facing you. If "◁" lights up instead, press once.

6 Turn REC LEVEL to adjust the recording level.

Turn REC LEVEL so that the peak level meters reach the recommended level for the corresponding tape type.

After you've done the adjustments, stop playing the program source.



For type I or type II tape

For type IV tape

To protect recordings against accidental erasure
Break out the record-protect tab(s) (see page 18).

7 Press PAUSE **||** or **▶**.
Recording starts.

8 Start playing the program source.

To	Press
Stop recording	■
Start recording from the reverse side	◀
Pause	PAUSE . Press the button again to resume recording.
Take out the cassette	☰ OPEN/CLOSE after stopping recording

Use these buttons (controls) for additional operations

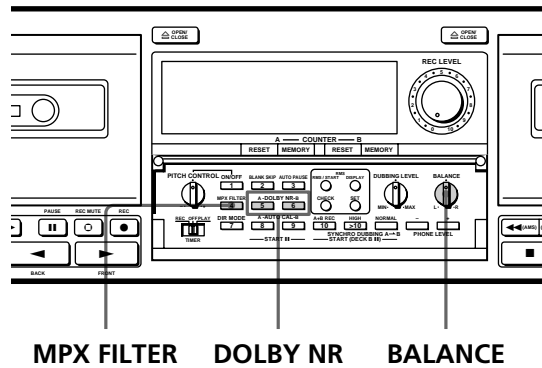

To check the approximate remaining time on a tape

- 1 Locate the end of the recorded portion on the tape and press RESET for the deck you're using to reset the tape counter to "0.00".
- 2 Press **▶▶** to fast-forward the tape to its end. The tape counter shows the approximate remaining time.

* Dolby noise reduction and HX Pro headroom extension manufactured under license from Dolby Laboratories Licensing Corporation. HX Pro originated by Bang & Olufsen.

"DOLBY", the double-D symbol **DD** and "HX PRO" are trademarks of Dolby Laboratories Licensing Corporation.

To adjust balance

Turn BALANCE so that L (left) and R (right) of the peak level meters in the display are at the levels you want.

To record with the Dolby NR* system

Press DOLBY NR repeatedly for the deck you're using to select B, C, or S before you start recording. "B," "C," or "S" appears in the display.

If you can't get satisfying results when recording FM broadcasts with the Dolby NR system

Press MPX FILTER (multiplex filter) (see page 22) with the Dolby NR system on. The filter turns on to make the Dolby NR system work more effectively. "FILTER" appears in the display.

Playing a Tape

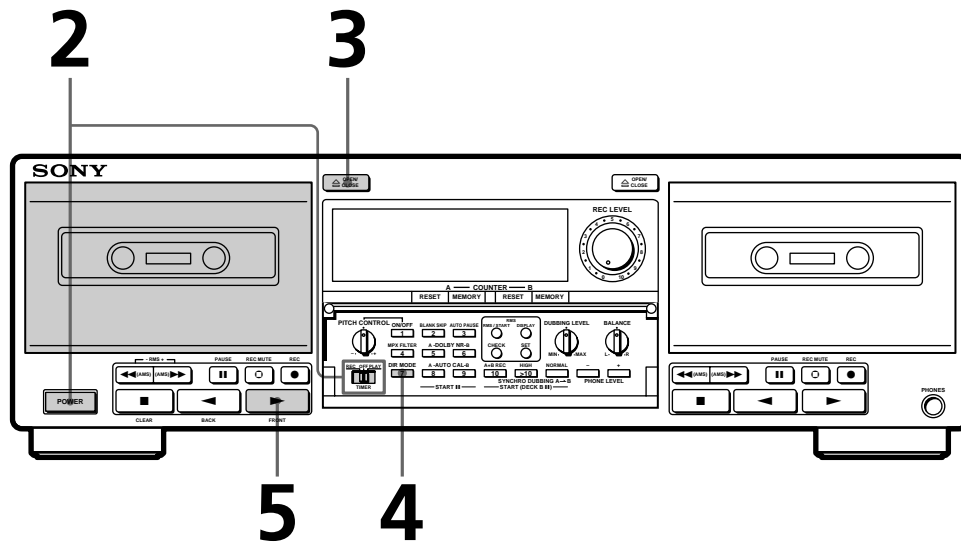

- See page 7 for hookup information.
- You can play a tape on either deck.

To adjust the pitch (Pitch Control function)

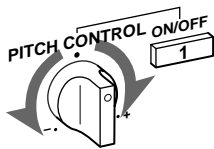

Press PITCH CONTROL ON/OFF so that "TAPE SPEED" appears in the display. Turn PITCH CONTROL clockwise to raise the pitch, or counterclockwise to lower it. You can adjust it during playback on deck A or normal-speed dubbing. Press PITCH CONTROL ON/OFF to turn off "TAPE SPEED" when not in use.

To play a tape recorded with the Dolby NR system
Press DOLBY NR repeatedly to select the same position that the tape was recorded in—B, C, or S.

You can connect the headphones to PHONES
You can adjust the headphone volume with PHONE LEVEL +/- . Press - to lower the volume, or + to raise it. The adjustment range is -∞ to 0 dB.

1 Turn on the amplifier and select the tape deck position.

2 Set TIMER to OFF and press POWER.

3 Press OPEN/CLOSE and insert a cassette, then press the button again to close the cassette holder.

With the side you want to play facing you.

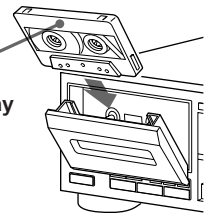

4 Select the direction mode.

To play back	Press DIR MODE repeatedly to select
One side only	
Both sides continuously*	
Both decks in succession*	RELAY

* The deck automatically stops after playing back five times.

5 Press .
The deck starts playing. Adjust the volume on the amplifier.

To	Press
Stop playing	
Start playback from the reverse side	
Pause	PAUSE . Press the button again to resume play.
Fast-forward or rewind	or when the deck is stopped
Take out the cassette	OPEN/CLOSE

Unpacking

Check that you received the following items:

- Audio connecting cords (2)
- Remote commander (remote) RM-J903 (1)*
- Sony size AA (R6) batteries (2)*

* not supplied with the U.S.A. and Canadian models

Inserting batteries into the remote

Insert two size-AA (R6) batteries, matching the + and - on the batteries with the markings inside the battery compartment. When using the remote, point it at the remote control sensor  on the tape deck.

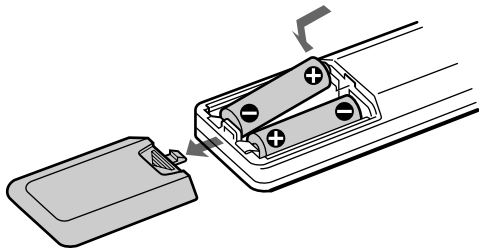

Hooking Up the System

This section describes how to hook up the tape deck to an amplifier. Be sure to turn off the power of each component before making the connections.

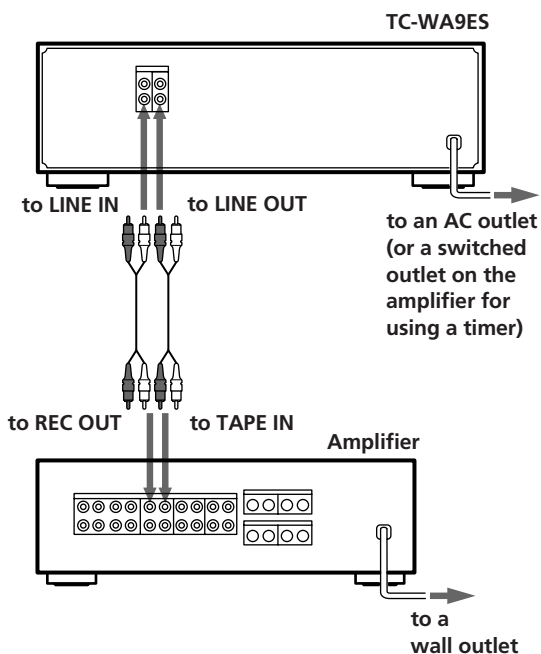

Hookups

Be sure to match the color-coded cord to the appropriate jacks on the components: Red (right) to Red and White (left) to White. Be sure to make connections firmly to avoid hum and noise. Connect the tape deck to the amplifier as shown below.

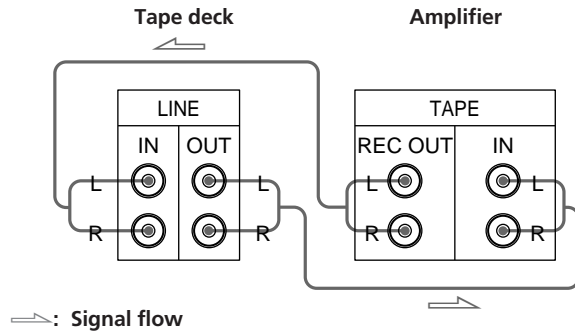

Connecting the tape deck to a Sony amplifier or a receiver through CONTROL S connectors (U.S.A. and Canadian models only)

Connect the components through the CONTROL S connectors using a CONTROL S cable (not supplied). When using this connection, the deck accepts only remote commands from the amplifier or receiver. The remote control sensor on the tape deck will not function.

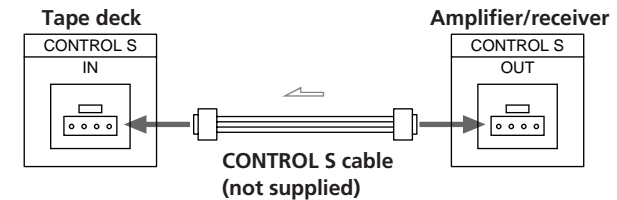

⇒: Signal flow

Note

For more information on the availability of Sony amplifier or receiver with a CONTROL S connector, contact your nearest Sony dealer.

Setting the voltage selector (not supplied with the U.S.A., Canadian, and Australian models)

Check that the voltage selector on the rear panel of the tape deck is set to the local power line voltage. If not, set the selector to the correct position using a screwdriver before connecting the AC power cord to an AC outlet.

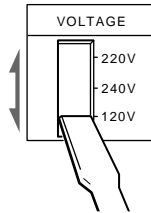

Connecting the AC power cord

Connect the AC power cord to an AC outlet.

Where do I go next?

Now you're ready to use your tape deck.

For basic operations, go to pages 4 to 6; for advanced operations, go to the sections immediately after this one.

Locating a Track (Multi-AMS/ Auto Play/Memory Play/Blank Skip)

You can locate the following/previous tracks within a range of 30 tracks (Multi-AMS: Automatic Music Sensor) or the beginning of a tape quickly (Auto Play). You can even locate a specific point anywhere on a tape (Memory Play) or automatically skip over blank spaces (Blank Skip).

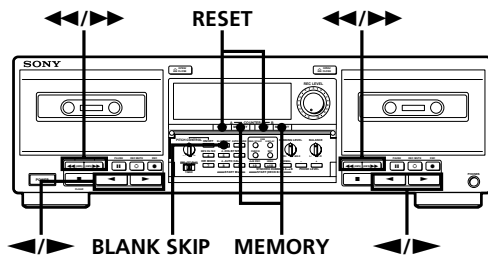

Note

Check the direction indicator of the deck you use. When you locate a track on the reverse side (when “◀” lights up), press the button(s) in the parentheses.

To locate	Press
The beginning of the next or succeeding tracks (Multi-AMS)	▶▶ (or ◀◀) as many times as you want during playback. For example, to locate 2 tracks ahead, press twice.
The beginning of the current track (Multi-AMS)	◀◀ (or ▶▶) once during playback
The beginning of the preceding tracks (Multi-AMS)	◀◀ (or ▶▶) as many times as you want during playback. For example, to locate 2 tracks behind, press three times.
The beginning of a tape (Auto Play)	MEMORY on the deck you’re using repeatedly until “MEMORY” disappears in the display. Then press ◀◀ (or ▶▶) while holding down ▶ (or ◀).
A particular point on a tape (Memory Play)	MEMORY on the deck you’re using repeatedly until “MEMORY” appears in the display. Find the point you want, then press RESET to reset the tape counter and to memorize the point. To locate the memorized point and start playback, press ◀◀ (or ▶▶) while holding down ▶ (or ◀). (Press ◀◀ or ▶▶ to stop at “0.00”.)
Tracks following spaces of 13 seconds or more (Blank Skip)	BLANK SKIP until “BLANK SKIP” appears in the display. Press again to turn off the function when not in use.

Note on the number indication in the display

The number indication in the display shows the number of times you’ve pressed ▶▶ (or ◀◀). During the deck is fast-forwarding (or rewinding), the number decreases one by one to indicate the number of tracks until the track you want to locate.



You can change the track you want to locate even while the deck is in Multi-AMS operation

Press ▶▶ (or ◀◀).

Notes

- The Multi-AMS function may not work correctly if:
 - the blank space between tracks is less than 4 seconds long.
 - there is a passage of low frequencies or very low volume within a track.
 - the signal strength of the left and right channels are very different.
- Even if DIR MODE is set to ◀, the deck stops when the current side reaches the end during Multi-AMS operation.
- Do not turn on the Pitch Control function (see page 6) while using the Blank Skip function on deck A. If you do, the Blank Skip function may not work properly.
- Since the counter is not a digital clock, it will differ from the actual elapsed playback or recording time.

Creating Your Own Program (RMS Play)

By creating a program, you can play back tracks on deck A in any order that you want. The Random Music Sensor (RMS) function lets you create a program of up to 30 tracks, from the 1st to the 15th track on each side of the tape.

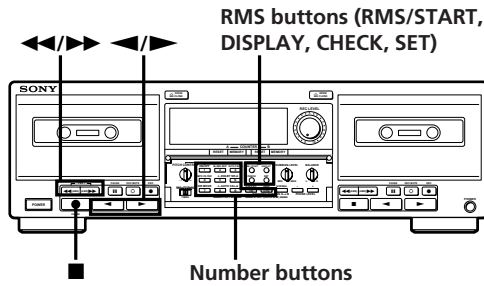

- 1 Press RMS/START.
"RMS" and a flashing cursor appear in the display.
- 2 Press ◀ (BACK) or ▶ (FRONT) to select the side of the tape.
"◀" or "▶" appears in the display.
- 3 Press number button(s) to enter the track number you want.

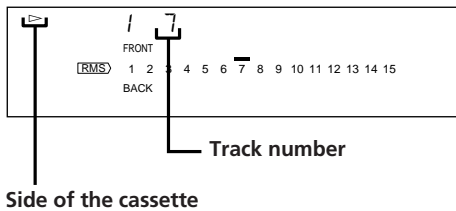

To enter a track number over 10

Press >10 first, and then the number.
Example: To enter 12; press >10, then 1 and 2.

To enter a track number using ▶▶, ◀◀, and SET

Press ▶▶ or ◀◀ repeatedly until the track number you want appears in the display, then press SET. To program the same track again, press SET once more.

- 4 Repeat Steps 2 and 3 to program more tracks.

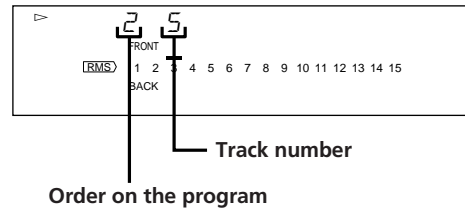

If "FULL" appears in the display

This means that you've already programmed 30 tracks and can't program any more.

- 5 Press RMS/START to start RMS Play.
The peak level meters appear in the display.

To stop RMS Play

Press ■ (CLEAR) once. The RMS program still remains.

To cancel RMS Play

Press ■ (CLEAR) repeatedly until the peak level meters appear in the display or eject the tape in deck A. When RMS Play is canceled, the RMS program is automatically erased.

To alternate between the RMS and peak level meter displays

Press DISPLAY.

You can play the program again after RMS Play ends

Press RMS/START.

Notes

- The RMS function may not work properly if a blank space between tracks is short.
- If there is a long blank space between tracks, the deck may fast-forward a portion of the blank space.
- If your program includes a number for a track that does not exist, the deck will skip that number during RMS Play.
- You can create an RMS program only when both decks are stopped.

Checking the order of tracks in the program

Press CHECK.

Each time you press this button, the display shows the track numbers in the order they were programmed. After the last track in the program, "End" appears in the display.

Adding tracks to the end of a program

Press ■ (CLEAR) once, and follow Steps 2 to 4 in “Creating Your Own Program (RMS Play)” on page 10.

To create another program

Press ■ (CLEAR) until the order on the program returns to 0 and the cursor flashes above track number 1 in the display, then follow Steps 2 to 4.

You can use your Sony stereo receiver's remote to perform RMS programming

If your Sony stereo receiver's remote has RMS buttons, do the following steps.

- 1 Turn on the receiver and press TAPE.
- 2 Press RMS/START.
- 3 Press ► or ◀ to select the front or reverse side of the tape, and the number keys (and the >10 key) to specify the tracks.
- 4 Press RMS/START again to start RMS Play.

Note

For more information on the availability of Sony stereo receiver remotes with RMS capability, contact your nearest Sony dealer.

Playing a Tape Using a Timer

You can start playing a tape at any time you want by connecting a timer (not supplied). Please refer to the instructions of the timer for further help.

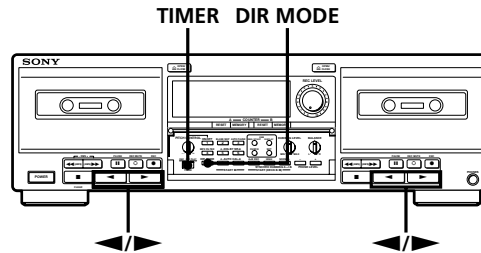

- 1 Insert (a) cassette(s) into either deck (or both decks). Make sure that the connections are correct (see page 7).
- 2 Prepare the tape deck for playback.
 - For single-deck playback**
Press DIR MODE repeatedly to select ⇄ or ↻, then press ► or ◀ to select the side of the tape.
 - For playback of both decks in succession**
Press DIR MODE repeatedly to select RELAY, then press ► or ◀ on deck A to select the side of the tape. (Playback on deck B always starts from the front side of the tape.)
- 3 Set TIMER on the tape deck to PLAY.
Before you set the timer in Step 4 below;
 - select the Dolby NR system (see page 6)
 - adjust the pitch (see page 6)
 - activate the Blank Skip function (see page 9)
- 4 Set the timer to the time you want.
The tape deck turns off. When the set time arrives, the tape deck turns on and starts playing.
- 5 After you have finished using the timer, set TIMER on the tape deck to OFF.

Note

If cassettes have been inserted into both decks for single-deck playback, playback will take place only on deck A.

Adjusting Bias and Recording Level Calibration Automatically

Since there are many different types of cassettes on the market, your tape deck automatically sets the appropriate equalization characteristics and bias current for each tape type (ATS: Automatic Tape Selection). However, you can get better recording results by doing the automatic bias current and the recording level calibration. You can do automatic calibration on either deck.

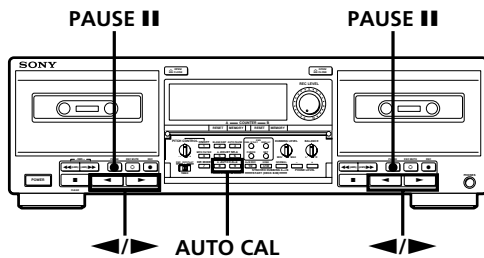

- 1 Insert the cassette you want to record on into either deck.
Make sure the record-protect tabs on the cassette have not been removed.
- 2 Press AUTO CAL for the deck you're using until "AUTO CAL" appears in the display.
- 3 Press ► or ◀ to select the side of the tape to be recorded.

To select	Press
The front side	►
The reverse side	◀

- 4 Press PAUSE II to start the automatic calibration procedure.
The automatic calibration procedure starts (i.e., recording test tones, rewinding, and playing back). During the calibration, the counter changes from 9 to 0.



When the automatic calibration procedure ends, the tape rewinds to the original position, the counter returns to normal and the tape deck stops.

- 5 Start the actual recording (see page 4).

To cancel the automatic calibration function

Press ■ on the deck you're using.

If "AUTO CAL" flashes continuously

The automatic calibration procedure has been interrupted by:

- The end of the tape. Reverse the tape direction or rewind the tape to a new position that allows recording of the test tone.
- Damaged tape or dirty heads. Change the cassette or clean and demagnetize the heads (see page 19).

Updating the calibration setting

If you insert a cassette into either deck A or B and "AUTO CAL" appears in the display, it means that automatic calibration data in that deck for that tape type (I, II or IV) exists. However, we recommend that you repeat the automatic calibration procedure each time you insert a new cassette since cassettes of the same type also vary in their characteristics.

Before recalibrating, be sure to turn off "AUTO CAL" in the display by pressing AUTO CAL. Then start from Step 2 of the automatic calibration procedure.

💡 To erase calibration data on either deck A or B

The automatic calibration data is stored even if you turn off the power (Memory Backup function). To erase the data, press ■ and RESET at the same time on the respective deck. "AUTO CAL" for that deck disappears, indicating that the data for the inserted tape type has been erased.

Notes

- Automatic calibration works only when both decks are stopped.
- You don't have to select the Dolby NR system when doing automatic calibration since the Dolby NR system does not affect the calibration results.

Dubbing a Tape

You can copy a tape in deck A to a tape in deck B at normal or high speed.

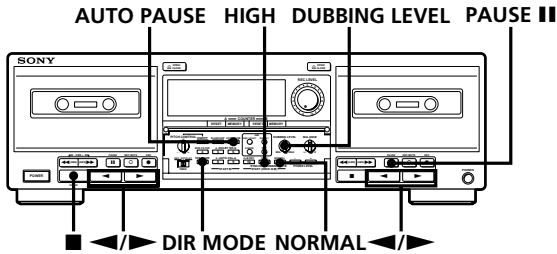

- 1 Insert the recorded cassette into deck A and a blank cassette into deck B. Make sure the record-protect tabs on the cassette in deck B have not been removed.

- 2 Select the side(s) to be recorded on.

To record on	Press DIR MODE repeatedly to select
One side	⇌
Both sides	↶. Recording on the reverse side on deck B starts independently of playback on deck A. RELAY. Recording on the reverse side on deck B starts simultaneously with playback of the reverse side on deck A.

- 3 Press HIGH or NORMAL to select the dubbing speed. "HIGH" or "NORM" appears in the display.

- 4 Select the side from which to start dubbing.

To record from	Press
The front side	▶
The reverse side	◀

- 5 Press PAUSE II on deck B to start dubbing.

To stop dubbing

During	Press
Normal-speed dubbing	■ on deck B
High-speed dubbing	■ on either deck

Additional tasks during normal-speed dubbing

You can make the following tasks only during normal-speed dubbing. During high-speed dubbing, only ■ works.

To	Do the following:
Adjust the dubbing level	Turn DUBBING LEVEL. To dub at the same level as the original, turn the control to the center-click position.
Select the Dolby NR system	See pages 5 and 6.
Adjust the pitch	See page 6.
Skip over blank spaces on the original	Press BLANK SKIP before you start dubbing (see page 9).

Note

If a TV set is placed near the tape deck, noise may occur during high-speed dubbing. In that case, turn the television set off or move it away from the tape deck.

💡 You can add fade-in/out during dubbing

Turn DUBBING LEVEL clockwise to fade in, or counterclockwise to fade out.

Dubbing only specific tracks (Auto Pause)

- 1 Press AUTO PAUSE before or during normal-speed dubbing. "AUTO PAUSE" appears in the display. At the end of each track, both deck A and deck B pauses.
- 2 Locate the track you want to record next on deck A (see page 9), then stop the tape.
- 3 Press PAUSE II on deck B to resume dubbing.

To cancel the Auto Pause function

Press AUTO PAUSE again to turn off "AUTO PAUSE" in the display.

Note

Do not turn on the Pitch Control function (see page 6) or Blank Skip Function (see page 9) while using the Auto Pause function. If you do, the Auto Pause function may not work properly.

(Continued)

Dubbing only specific portions

You can do this only during normal-speed dubbing.

- 1 Press ■ on deck A at the portion you want to skip. Deck B changes to recording pause.
- 2 Locate the point you want to resume recording on deck A, then stop the tape.
- 3 Press PAUSE || on deck B to resume dubbing.

Recording on Both Decks in Succession (Relay Recording)

You can make a continuous recording that starts on a cassette in deck A and ends on a cassette in deck B.

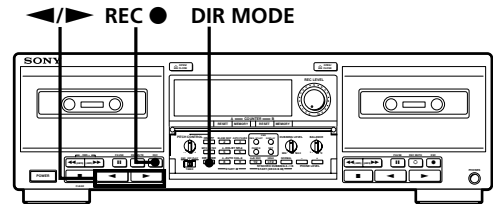

- 1 Insert blank cassettes into both decks. Make sure that record-protect tabs on the cassettes have not been removed.
- 2 Select the Dolby NR system for both decks (see page 5).
- 3 Press DIR MODE repeatedly until "RELAY" appears in the display.
- 4 Press REC ● on deck A. Deck A changes to recording pause.
- 5 Start playing the program source.
- 6 Adjust the recording level and balance (see pages 4 and 5).
- 7 Start recording.

To record from	Press
The front side	▶ on deck A
The reverse side	◀ on deck A

To stop Relay Recording

During	Press
Recording on deck A	■ on deck A
Recording on deck B	■ on deck B

Note

Make sure that "▷" on deck B appears in the display. If it doesn't, press ▶ on deck B once; otherwise, Relay Recording stops when the reverse side of the cassette in deck B finishes.

Recording the Same Source on Both Decks (Simultaneous Recording)

You can record the same source on cassettes in deck A and B at the same time.

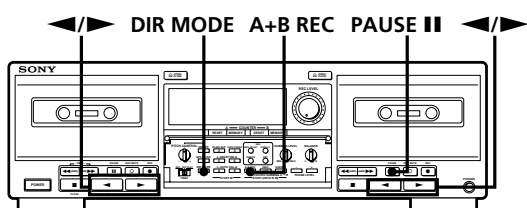

- 1 Insert blank cassettes into both decks. Make sure that record-protect tabs on the cassettes have not been removed.
- 2 Select the Dolby NR system for both decks (see page 5).
- 3 Select the side(s) to be recorded on.

To record on	Press DIR MODE repeatedly to select
Only one side	→
Both sides	↻

- 4 Press A+B REC. Both decks change to recording pause.
- 5 Start playing the program source.
- 6 Adjust the recording level and balance (see pages 4 and 5).
- 7 Select the side you want to start recording from on both decks.

To record from	Press
The front side	▶
The reverse side	◀

- 8 Press PAUSE II on deck B. Simultaneous Recording starts.

To stop Simultaneous Recording

Press ■ on both decks.

💡 PAUSE II and REC MUTE ○ (see page 16) on deck B can control both decks at the same time

During Simultaneous Recording, PAUSE II and REC MUTE ○ on deck B control both decks, but not PAUSE II and REC MUTE ○ on deck A.

Recording Your Own Program (RMS Dubbing)

You can record an RMS program that you've created (see "Creating Your Own Program (RMS Play)" on page 10). This function works only at normal speed.

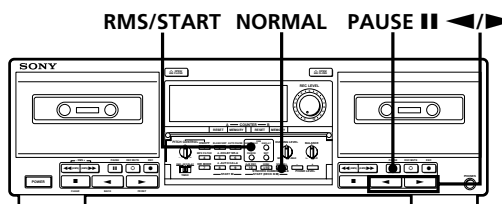

- 1 Insert the recorded cassette into deck A and a blank cassette into deck B. Make sure the record-protect tabs on the cassette in deck B have not been removed.
- 2 Program tracks on deck A (see Steps 1 to 4 on page 10).
- 3 Press NORMAL to change the tape deck to dubbing standby.
- 4 Select the side of the tape in deck B you want to record on.

To start recording	Press
On the front side	▶
On the reverse side	◀

- 5 Press RMS/START or PAUSE II on deck B to start RMS Dubbing.

To stop RMS Dubbing

Press ■ on deck B. The RMS program remains even after RMS Dubbing stops.

💡 To insert a blank space on the tape before you start RMS Dubbing

You can insert a blank space of 4 seconds or more on the tape in deck B by pressing REC MUTE ○ on deck B after Step 4.

For details, see "Inserting a Blank Space During Recording (Record Muting)" on page 16.

💡 A blank of 10 seconds is automatically inserted on the tape when you start RMS Dubbing if:

- you insert a new cassette into deck B.
- the tape in deck B is completely rewound to its beginning and automatically stopped.

Inserting a Blank Space During Recording (Record Muting)

You can insert a blank space of 4 seconds between each track. The blank spaces allow you to locate the start of specific tracks afterwards using the Multi-AMS function (see page 9). You can also use this function to erase unwanted portions on a tape.

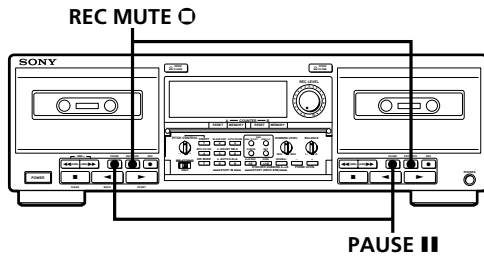

- 1 Start recording on either deck.
- 2 Press REC MUTE ○ where you want to insert a blank space. "REC" flashes in the display and a blank is recorded on the tape. After 4 seconds, "■■" lights up and the tape deck changes to recording pause.
- 3 Press PAUSE ■■ to resume recording.

💡 If you want to insert a blank space longer than 4 seconds

Hold down REC MUTE ○ as long as you want. After 4 seconds, "REC" flashes faster.

When you release REC MUTE ○, "■■" lights up and the tape deck changes to recording pause.

Press PAUSE ■■ to resume recording.

Synchro-Recording With a CD Player

(Not Available on U.S.A. and Canadian Models)

By pressing CD SYNCHRO START on the remote (not supplied with U.S.A. and Canadian models), you can perform synchro-recording on your tape deck with a Sony CD player. This function is possible only with Sony CD players with remote control capability.

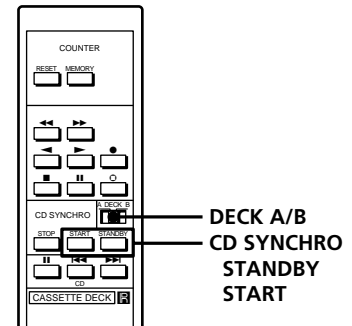

- 1 Insert a CD into the CD player.
- 2 Insert a cassette into deck B.
- 3 Set DECK A/B to B.
- 4 Press CD SYNCHRO STANDBY. The CD player changes to play pause and deck B to recording pause.
- 5 Press CD SYNCHRO START. Deck B starts recording, and then the CD player starts playing.

To pause Synchro-Recording

Press ■■ on the tape deck and CD player simultaneously. Press both buttons again to resume Synchro-Recording.

To stop Synchro-Recording

Press CD SYNCHRO STOP.

💡 You can use the remote of your tape deck to operate the CD player

To start CD play, press ■■ twice; to pause CD play, press ■■ once; to locate a CD track, press ◀◀ or ▶▶.

Recording Using a Timer

You can start recording on a tape at any time you want by connecting a timer (not supplied). Please also refer to the instructions of the timer for further help.

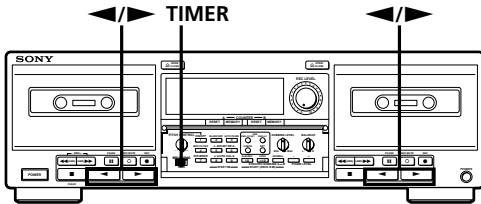

- 1 Insert (a) cassette(s) into either deck (or both decks). Make sure that the connections are correct (see page 7).
- 2 Turn on the amplifier and play the program source you want to record.
- 3 Prepare the tape deck for recording.
 - For single-deck recording**
Follow Steps 4 to 6 on page 4, and press ► or ◀ to select the side of the tape.
 - For recording on both decks**
 - For Relay Recording, follow Steps 2 to 4, and 6 on page 14.
 - For Simultaneous Recording, follow Steps 2 to 4, 6, and 7 on page 15.
- 4 On the tape deck, set TIMER to REC.
Before you set the timer in Step 5 below;
 - select the Dolby NR system (see page 5)
 - turn on the multiplex filter (see page 5)
 - do automatic calibration (see page 12)
- 5 Set the timer to the time you want.
The tape deck turns off. When the set time comes, the tape deck turns on and starts recording.
- 6 After you have used the timer, set TIMER on the tape deck to OFF.

Notes

- Do not leave the TIMER switch at REC, or the tape deck will automatically start recording the next time you turn on the tape deck.
- During timer recording, recording starts from the side of the tape being used when the power turns off.
In Relay Recording, however, recording on deck B always starts from the front side of the tape.
- Do not insert cassettes into both decks when you do single-deck recording. If cassettes are inserted into both decks and “◄” or “►” appears in the display, Simultaneous Recording will start and the same material will be recorded on both tapes.

Precautions

On safety

- Do not disassemble the cabinet — this may result in an electrical shock. Refer servicing to qualified personnel only.
- Should any solid object or liquid fall into the cabinet, unplug the tape deck and have it checked by qualified personnel before operating it any further.

On power sources

- Before operating the tape deck, check that the operating voltage of the tape deck is identical with your local power supply. The operating voltage is indicated on the nameplate at the rear of the tape deck.
- If you are not going to use the tape deck for a long time, be sure to disconnect the tape deck from the wall outlet. To disconnect the AC power cord, grasp the plug itself; never pull the cord.

On operation

Because of a safety mechanism, the function buttons will not operate if the cassette holder is not completely closed, if there is no cassette in the cassette holder, or if a cassette has been incorrectly inserted into the cassette holder.

On placement

- Place the tape deck in a location with adequate ventilation to prevent heat build-up in the tape deck.
- Do not place the tape deck:
 - on a soft surface such as a rug that might block the ventilation holes on the bottom.
 - in a location near heat sources.
 - in a place subject to direct sunlight.
 - in an inclined position.
 - in a place subject to excessive dust or mechanical shock.

On cleaning the tape deck

Clean the cabinet, panel and controls with a soft cloth slightly moistened with a mild detergent solution. Do not use any type of abrasive pad, scouring powder or solvent such as alcohol or benzine.

For the customers in the U.S.A.

For detailed safety precautions, see the leaflet "IMPORTANT SAFEGUARDS".

If you have any questions or problems concerning your tape deck, please consult your nearest Sony dealer.

Notes on Cassette Tapes

To protect a recording on side A or B

Break out the respective tab.

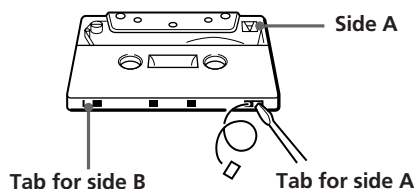

To record on a tape with a missing record-protect tab

Cover the respective tab hole with adhesive tape.

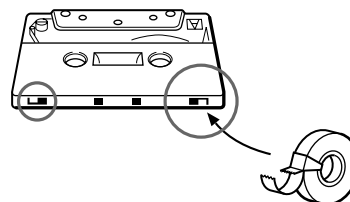

When you are using a type II or type IV tape, be careful not to cover the detector slots that the deck uses to determine the tape type.

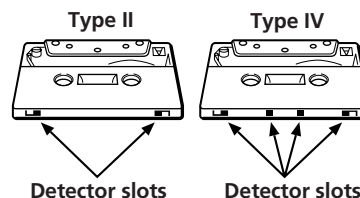

On tapes longer than 90 minutes

We do not recommend the use of tapes longer than 90 minutes except for a long continuous recording or playback. They are very thin and tend to stretch easily.

On handling cassettes

- To prevent the heads and tape path from getting dirty, avoid touching the tape surface of a cassette.
- Place cassettes away from equipment with magnets, such as speakers and amplifiers, which may cause tape distortion or erase the recordings.
- Do not expose cassettes to direct sunlight, extremely cold temperature, or moisture.

Cleaning

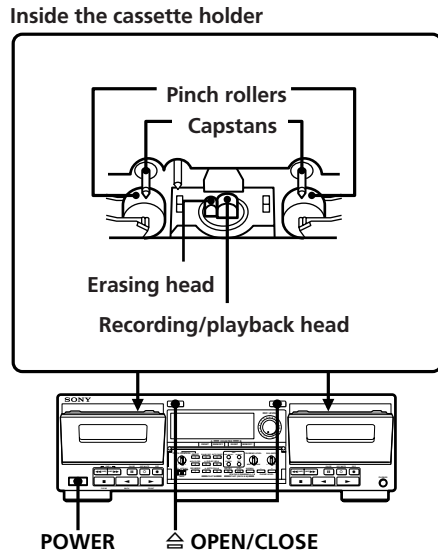

Demagnetizing the heads

After 20 to 30 hours of use, or when you notice a hissing sound or loss of high frequencies, demagnetize the heads with a commercially available demagnetizer for tape decks. Please refer to the instructions of the demagnetizer.

Cleaning the heads and tape path

Clean the heads and tape path of the tape deck after every 10 hours of operation to guard against:

- low-quality sound
- a decrease in sound level
- excessive wow or flutter
- sound dropout
- incomplete erasure
- impairment of recording function

To ensure better recording, we recommend that you clean the heads and tape path before every recording.

- 1** Turn on the tape deck.
- 2** Set the volume control on the amplifier to minimum.
- 3** Press \triangle OPEN/CLOSE to open the cassette holder.
- 4** Wipe the heads, the pinch rollers and the capstans with a cotton swab slightly moistened with alcohol or a commercially available cleaning fluid for tape decks.
Do not insert a cassette until the cleaned areas are completely dry.

Troubleshooting

If you've experienced any of the following difficulties while using the tape deck, use this troubleshooting guide to help you remedy the problem. Should the problem persist, consult your nearest Sony dealer.

The function buttons do not work.

- ➔ The tape deck has been just turned on and does not operate for about 3 seconds. Wait until "II" stops flashing.
- ➔ Check that the cassette is inserted correctly and the cassette holder is closed completely.

Playback or recording begins when the power is turned on.

- ➔ Set TIMER on the tape deck to OFF.

The tape deck does not play or record.

- ➔ There is no cassette in the cassette holder.
- ➔ The cassette holder is not completely closed.
- ➔ The tape has come to the end.
- ➔ The tape is slack. Take up the tape slack.
- ➔ The record-protect tab has been removed from the cassette (see page 18).
- ➔ Make sure the amplifier setting is correct.
- ➔ Check that the tape deck connections are secure.
- ➔ The heads and tape path are dirty. Clean them (see page 19).
- ➔ The recording/playback head is magnetized. Demagnetize it (see page 19).

There is excessive wow, flutter or sound drop-out.

- ➔ The capstans and pinch rollers are dirty. Clean them (see page 19).

There is a decrease in sound level, sound drop-out, or poor reproduction of high frequencies./The tape does not erase completely./Noise increases.

- ➔ The recording/playback head and tape path are dirty. Clean them (see page 19).
- ➔ The recording/playback head is magnetized. Demagnetize it (see page 19).

There is hum or noise.

- ➔ The tape deck is placed near a TV or VCR. Move the tape deck away from the TV or VCR.
- ➔ The tape deck is placed on or under the amplifier. Move the tape deck away from the amplifier.

There is an unbalanced tone.

- ➔ Check that DOLBY NR setting is the same as when the tape was recorded.
- ➔ The tape deck is placed near a TV or VCR. Move the tape deck away from the TV or VCR.

The tape stops before the tape has been fully rewound.

- ➔ The tape is slack. Take up the tape slack.
- ➔ If "MEMORY" is shown in the display, press MEMORY repeatedly until "MEMORY" disappears.
- ➔ The cassette shell is bent. Use another cassette.

The Multi-AMS function does not work properly.

- ➔ One of the tracks contains a long pause, a passage of low frequencies or very low volume, or a gradual increase or decrease in volume.
- ➔ The space before a track is less than 4 seconds long. Insert a blank space of 4 seconds using REC MUTE \square .
- ➔ The signal strength of the left and right channels are very different.
- ➔ There is noise in the space before a track.
- ➔ You pressed $\blacktriangleright\blacktriangleright$ (or $\blacktriangleleft\blacktriangleleft$) immediately before the beginning of the next track or immediately after the beginning of the current track.

The tape deck fast-forwards the tape while a track is playing.

- ➔ The tape deck's Blank Skip function is on and silent or low-volume portions are skipped. Press BLANK SKIP to turn off "BLANK SKIP" in the display.

The Dolby NR function does not work during playback.

- ➔ The Pitch Control function is on and the frequency characteristics of the sound is altered. Press PITCH CONTROL ON/OFF to turn off the function.

There is excessively loud tape transport noise during fast-forwarding or rewinding.

- ➔ This noise is caused by the cassette and is not a mechanical problem.

$\triangleleftrightsquigarrow$ OPEN/CLOSE does not work.

- ➔ The tape deck is recording. Press \blacksquare to stop recording before pressing $\triangleleftrightsquigarrow$ OPEN/CLOSE.
- ➔ There has been a power failure or the power cord has been disconnected during tape operation. Reconnect the power.

Specifications

System

Recording system

4-track 2-channel stereo

Fast-winding time (approx.)

90 sec. (with Sony C-60 cassette)

Bias

AC bias

Signal-to-noise ratio (at peak level, weighted, and with Dolby NR off)

Type I tape, Sony Type I (NORMAL): 56 dB

Type II tape, Sony Type II (HIGH): 58 dB

Type IV tape, Sony Type IV (METAL): 59 dB

S/N ratio improvement (approximate values)

With Dolby B NR on: 5 dB at 1 kHz, 10 dB at 5 kHz

With Dolby C NR on: 15 dB at 500 Hz, 20 dB at 1 kHz

With Dolby S NR on: 10 dB at 100 Hz, 24 dB at 1 kHz

Harmonic distortion

0.4 % (with Type I tape, Sony Type I (NORMAL):
160 nWb/m 315 Hz, 3rd H.D.)

1.8 % (with Type IV tape, Sony Type IV (METAL):
250 nWb/m 315 Hz, 3rd H.D.)

Frequency response (Dolby NR off)

Type I tape, Sony Type I (NORMAL): 25 - 16,000 Hz
(±3 dB, IEC)

Type II tape, Sony Type II (HIGH): 25 - 18,000 Hz
(±3 dB, IEC)

Type IV tape, Sony Type IV (METAL): 25 - 20,000 Hz
(models for the U.S.A. and Canada), 25 - 19,000 Hz
(models for other countries) (±3 dB, IEC)

30 - 15,000 Hz (±3 dB, -4 dB recording)

Wow and flutter

±0.09% W. Peak (IEC)

0.06% W. RMS (NAB)

±0.16% W. Peak (DIN)

Variable pitch range (approx.)

-30 to +30%

Inputs

Line inputs (phono jacks)

Sensitivity : 0.16 V

Input impedance : 47 kilohms

Outputs

Line outputs (phono jacks)

Rated output level : 0.5 V at a load impedance of
47 kilohms

Load impedance : Over 10 kilohms

Headphones (stereo phone jack)

Output level : 0 to 3 mW at a load impedance of
32 ohms

General

Power requirements

Where purchased	Power requirements
U.S.A. and Canada	120 V AC, 60 Hz
Australia	240 V AC, 50/60 Hz
Other countries	120/220/240 V AC, 50/60 Hz

Power consumption

30 W

Dimensions (approx) (w/h/d)

430 × 135 × 350 mm (w/h/d)

(17 × 5 ³/₈ × 13 ⁷/₈ inches)

including projecting parts and controls

Mass (approx.)

6.5 kg (14 lbs 6 oz)

Supplied accessories

Audio connecting cords (2 phono plugs - 2 phono
plugs) (2)

Remote commander RM-J903 (1)*

Sony size AA (R6) batteries (2)*

* not supplied with the U.S.A. and Canadian models

Design and specifications are subject to change without
notice.

Glossary

ATS

Automatic Tape Selection. The tape deck automatically sets the appropriate equalization characteristics and bias current according to the type of tape inserted in the deck.

Automatic calibration

The automatic adjustment of the bias current and recording level for the inserted tape.

This adjustment works together with the deck's ATS (Automatic Tape Selection, see above) to get the best possible recording results on any tape.

Dolby HX PRO system

A system that reduces distortion and noise in high-frequency response during recording. A tape recorded with this system produces the same high-quality sound even when played on other tape decks.

Dolby NR (noise reduction) system

A system that eliminates tape hiss noise by boosting low-level signals in the high-frequency range during recording, then lowering them during playback.

There are four types of systems: A, B, C and S. Type A is for professional use (not available on your tape deck), and types B, C and S are for consumer use. Type S has the maximum noise reduction capability, followed by types C and B.

Memory backup function

A function for storing settings even after the power is turned off. The settings stored include:

- counter and counter memory settings
- multiplex filter and Dolby NR settings
- automatic calibration data
- pitch adjustment, tape direction, and headphone volume settings.

To reset parameters to their original factory settings, turn on the tape deck while holding down the RESET buttons of both decks A and B.

Multi-AMS

Multi-Automatic Music Sensor is a function that locates the beginning of up to 30 tracks before or after the current track by detecting the blank space (of over 4 seconds) between tracks.

Multiplex filter

A filter for eliminating the 19-kHz stereo carrier and the 38-kHz sub-carrier signals that may impair the Dolby NR system. Though tuners are usually equipped with this filter, if you got poor results when recording FM broadcasts with the Dolby NR system, your tuner may not have a filter or the filter may not be working. In this case, press the MPX FILTER button on the tape deck.

Quick reverse function

A function that quickly reverses the tape direction as soon as the tape deck detects the leader tape. This allows recording or playback to continue without a break even when the tape reaches the end. The quick reverse function does not operate and the deck does not reverse the tape direction until the tape ends completely when :

- you start recording on the tape or begin playing the tape right before the start of the leader tape (less than 10 seconds before).
 - the leader tape is made of dark material that impedes the passage of light.
 - the leader tape has a striped pattern.
 - there is no leader tape in the cassette.
 - the base material for the magnetic coating is thin, as in a 120-minute tape.
- The tape deck may reverse the tape direction in the middle of the tape if:
- there are folds, wrinkles, oil stains, or uneven patches of magnetic coating on the tape.
 - the quick reverse sensor is exposed to direct sunlight or other strong light sources.

Tape counter

A display element that shows the elapsed recording or playing time as a digital readout. Since the counter is not a digital clock, the displayed value will differ slightly from the actual elapsed recording or playing time. The counter value also includes the length of the leader tape. When deck A and B are operated at the same time, a slight difference may develop between both counters.

Test tones

Signals (10-kHz and 400-Hz) generated by the tape deck for bias current and recording level calibration.

Index

A

- Adjusting
 - balance 5
 - bias and recording level calibration. *See* Automatic calibration
 - headphone level 6
 - pitch. *See* Pitch control function
 - recording level 4
- ATS 12, 22
- Auto pause 13
- Auto play 9
- Automatic calibration 12, 22
- Automatic tape selection. *See* ATS

B

- Blank skip 9

C

- Cassette. *See* Tape
- Checking
 - remaining time 5
- Cleaning
 - heads and tape path 19
 - tape deck 18
- CONTROL S cable 7
- Cord
 - AC power 8
 - audio connecting 7

D, E, F

- Dolby HX PRO system 5, 22
- Dolby NR system 5, 6, 22
- Dubbing
 - high-speed dubbing 13
 - normal-speed dubbing 13
 - only specific portions 14
 - only specific tracks. *See* Auto pause

G

- Glossary 22

H

- Heads
 - cleaning 19
 - demagnetizing 19
- Hooking up
 - tape deck to the amplifier 7
 - through CONTROL S connectors 7

I, J, K

- Inserting
 - batteries into the remote 7
 - blank space during recording. *See* Record muting
 - cassette 4, 6

L

- Locating
 - beginning of a tape. *See* Auto play
 - particular point. *See* Memory play
 - tracks 9
 - tracks following spaces. *See* Blank skip

M, N, O

- Memory backup function 12, 22
- Memory play 9
- Multi-AMS 9, 16, 22
- Multiplex filter 5, 22

P, Q

- Pitch control function 6
- Playing
 - basic playing 6
 - timer playback 11
- Precautions 18

R

- Random Music Sensor. *See* RMS dubbing or play
- Record muting 16
- Recording
 - basic recording 4
 - CD synchro-recording 16
 - FM broadcasts 5
 - on both decks in succession. *See* Relay recording
 - the same source on both decks. *See* Simultaneous recording
 - timer recording 17
- Relay recording 14
- Remote 7, 16
- RMS dubbing 15
- RMS play
 - adding tracks 11
 - checking the order of tracks 10

S

- Simultaneous recording 15
- Specifications 21
- Supplied accessories 7, 21

T

- Tape
 - protecting recordings 5, 18
 - record-protect tab 5, 18
 - taking out 5, 6
 - type 12, 18
- Test tones 22
- Troubleshooting 20

U, V, W, X, Y, Z

- Unpacking 7

Names of Controls

Buttons

- A+B REC (simultaneous recording) 15
- AUTO CAL 12
- AUTO PAUSE 13
- BLANK SKIP 9
- CHECK 10
- DISPLAY 10
- DOLBY NR 5, 6
- HIGH 13
- MEMORY 9
- MPX FILTER 5
- NORMAL 13, 15
- Number buttons 10
- PHONE LEVEL +/- 6
- PITCH CONTROL ON/OFF 6
- RESET 5, 9
- RMS/START 10, 15
- SET 10
- STANDBY 16
- START 16
- ▶ (forward play/RMS FRONT) 4 - 6, 9 - 15, 17
- ◀ (reverse play/RMS BACK) 5, 6, 9 - 15, 17
- ▶▶, ◀◀ (fast-forwarding and rewinding/AMS/RMS +/-) 5, 6, 9, 10
- (stop/RMS CLEAR) 5, 6, 10, 13
- PAUSE ■■ 5, 6, 12, 13, 15, 16
- REC (recording) ● 4, 14
- REC MUTE (record muting) ○ 16
- ⊕ OPEN/CLOSE 4, 5, 6, 19

Switches

- DECK A/B 16
- DIR MODE 4, 6, 11, 13 - 15
- POWER 4, 6, 19
- TIMER 4, 6, 11, 17

Controls

- BALANCE 5
- DUBBING LEVEL 13
- PITCH CONTROL 6
- REC (recording) LEVEL 4

Connector

- CONTROLS 7

Jacks

- LINE IN 7
- LINE OUT 7
- PHONES 6

Others

- Cassette holder 4, 6, 19
- Peak level meters 4, 5, 10
- Remote control sensor 7
- Voltage selector 8

