

FM/MW/LW Compact Disc Player

Installation/Connections
 Installation/Anschluss
 Installation/Connexions
 Installazione/Collegamenti
 Montage/Aansluitingen

CDX-GT23

© 2007 Sony Corporation Printed in Thailand

2

* from car antenna (aerial) von Autoantenne de l'antenne de la voiture dall'antenna dell'auto van een auto-antenne

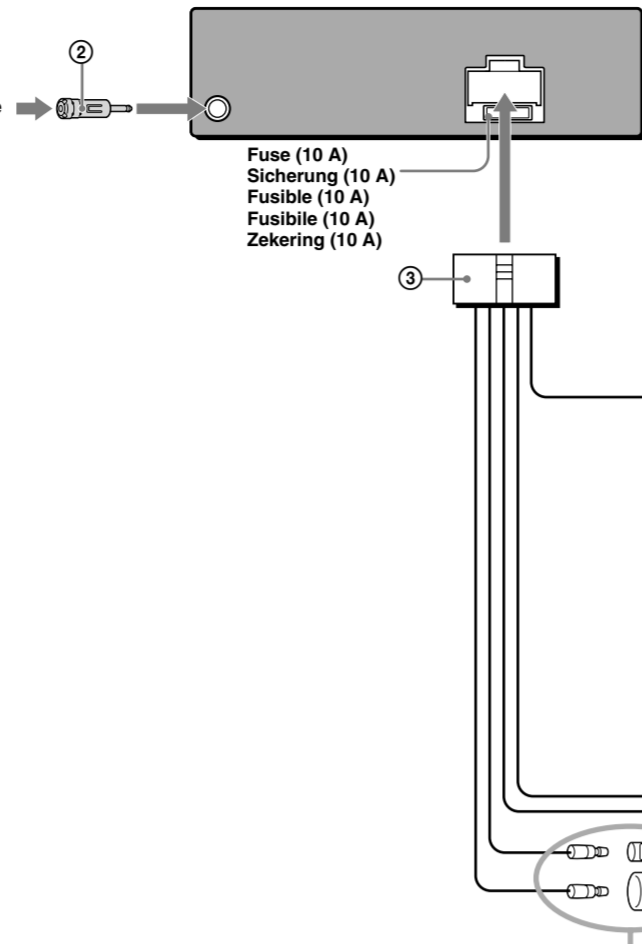

* Note for the antenna (aerial) connecting If your car antenna (aerial) is an ISO (International Organization for Standardization) type, use the supplied adaptor (2) to connect the car antenna (aerial) to the supplied adaptor, then connect it to the antenna (aerial) jack of the master unit.

* Hinweis zum Anschließen der Antenne Wenn Ihre Autoantenne der ISO-Norm (Internationale Normungsgemeinschaft) entspricht, schließen Sie sie mithilfe des mitgelieferten Adapters (2) an. Verbinden Sie zuerst die Autoantenne mit dem mitgelieferten Adapter und verbinden Sie diesen dann mit der Antennenbuchse des Hauptgeräts.

* Remarque sur le raccordement de l'antenne Si votre antenne de voiture est de type ISO (Organisation internationale de normalisation), utilisez l'adaptateur fourni (2) pour la raccorder. Raccordez d'abord l'antenne de voiture à l'adaptateur fourni et, ensuite, à la prise d'antenne de l'appareil principal.

* Nota per il collegamento dell'antenna Se l'antenna dell'auto è di tipo ISO (International Organization for Standardization), utilizzare l'adattatore (2) in dotazione per collegarla. Collegare prima l'antenna della macchina all'adattatore in dotazione, quindi collegarla alla presa dell'antenna dell'apparecchio principale.

* Opmmerking bij de antenne-aansluiting Indien uw auto is uitgerust met een antenne van het type ISO (International Organization for Standardization), moet u die aansluiten met behulp van de bijgeleverde adapter (2). Sluit eerst de auto-antenne aan op de bijgeleverde adapter en vervolgens de antennenstekker op het hoofdtoestel.

1	Purple Violet Viola Paars	+	Speaker, Rear, Right Lautsprecher hinten rechts Haut-parleur, arrière, droit Diffusore, posteriore, destro Luidspreker, achter, rechts	5	White Weiß Blanc Wit	+	Speaker, Front, Left Lautsprecher vorne links Haut-parleur, avant, gauche Diffusore, anteriore, sinistro Luidspreker, voor, links
2		-	Speaker, Rear, Right Lautsprecher hinten rechts Haut-parleur, arrière, droit Diffusore, posteriore, destro Luidspreker, achter, rechts	6		-	Speaker, Front, Left Lautsprecher vorne links Haut-parleur, avant, gauche Diffusore, anteriore, sinistro Luidspreker, voor, links
3	Gray Grau Gris Grijs	+	Speaker, Front, Right Lautsprecher vorne rechts Haut-parleur, avant, droit Diffusore, anteriore, destro Luidspreker, voor, rechts	7	Green Grün Vert Verde	+	Speaker, Rear, Left Lautsprecher hinten links Haut-parleur, arrière, gauche Diffusore, posteriore, sinistro Luidspreker, achter, links
4		-	Speaker, Front, Right Lautsprecher vorne rechts Haut-parleur, avant, droit Diffusore, anteriore, destro Luidspreker, voor, rechts	8		-	Speaker, Rear, Left Lautsprecher hinten links Haut-parleur, arrière, gauche Diffusore, posteriore, sinistro Luidspreker, achter, links

Negative polarity positions: 2, 4, 6, and 8 have striped leads. An den negativ gepoolten Positionen 2, 4, 6 und 8 befinden sich gestreifte Adern. Le posizioni di polarità negativa 2, 4, 6 e 8 hanno nastri pas de broches. Le posizioni a polarità negativa 2, 4, 6 e 8 hanno nastri pas de broches. De positieve voor negatieve polariteit (2, 4, 6 en 8) hebben gestreepte kabels.

4	Yellow Gelb Giallo Geel		continuous power supply permanente Stromversorgung alimentazione continua alimentazione continua voeding	7	Red Rot Rouge Rosso Rood		switched power supply geschaltete Stromversorgung alimentazione commutata alimentazione commutata geschakelde voeding
5	Blue Blau Bleu Blauw		power antenna (aerial) control Motorantennensteuerung commande d'antenne électrique comando dell'antenna elettrica elektrische antenne	8	Black Schwarz Noir Zwart		ground (earth) Masse masse terra aarding

Positions 1, 2, 3, and 6 do not have pins. An Position 1, 2, 3 und 6 befinden sich keine Stifte. Les positions 1, 2, 3 et 6 ne comportent pas de broches. Le posizioni 1, 2, 3 e 6 non hanno pinnelle. De positieven 1, 2, 3 en 6 hebben geen pins.

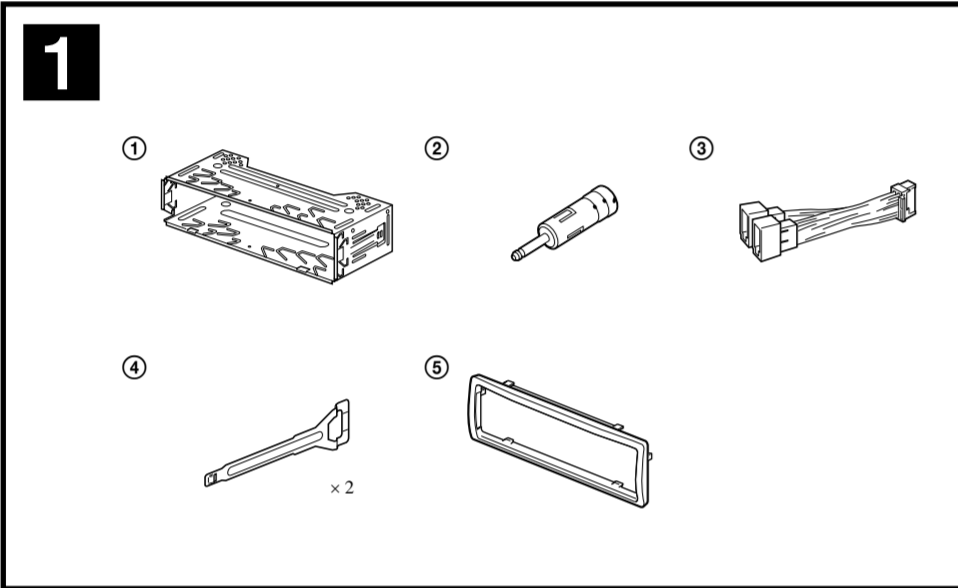

Equipment used in illustrations (not supplied)
 In Abbildungen dargestellte Geräte (nicht mitgeliefert)
 Appareils utilisés dans les illustrations (non fournis)
 Apparecchiatura utilizzata nelle illustrazioni (non in dotazione)
 Apparatuur gebruikt in de afbeeldingen (niet bijgeleverd)

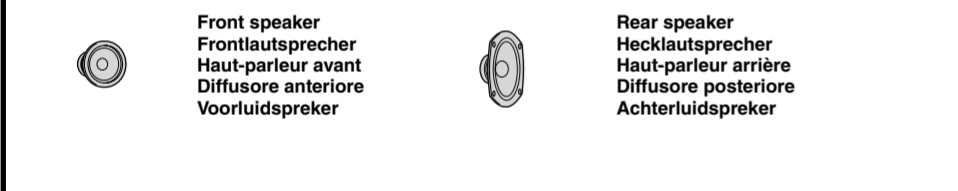

Connection example
 Anschlussbeispiel
 Exemple de raccordement
 Esempio di collegamento
 Voorbeeldaansluitingen

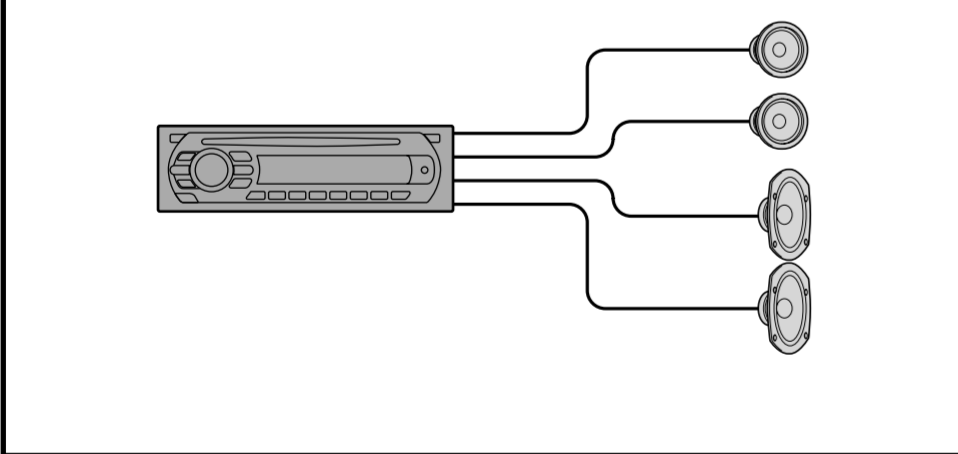

Cautions

- This unit is designed for negative ground (earth) 12 V DC operation only.
- Do not get the leads under a screw, or caught in moving parts (e.g. seat railing).
- Before making connections, turn the car ignition off to avoid short circuits.
- Connect the power supply lead (2) to the unit and speakers before connecting it to the auxiliary power connector.
- Run all ground (earth) leads to a common ground (earth) point.
- Be sure to insulate any loose unconnected leads with electrical tape for safety.

Notes on the power supply lead (yellow)

- When connecting this unit in combination with other stereo components, the connected car circuit's rating must be higher than the sum of each component's fuse.
- When no car circuits are rated high enough, connect the unit directly to the battery.

Parts list

- The numbers in the list are keyed to those in the instructions.
- The bracket (1) and the protection collar (2) are attached to the unit before shipping. Before mounting the unit, use the release keys (3) to remove the bracket (1) and the protection collar (2) from the unit. For details, see "Removing the protection collar and the bracket (1)" on the reverse side of the sheet.
- Keep the release keys (3) for future use as they are also necessary if you remove the unit from your car.

Caution Handle the bracket (1) carefully to avoid injuring your fingers.

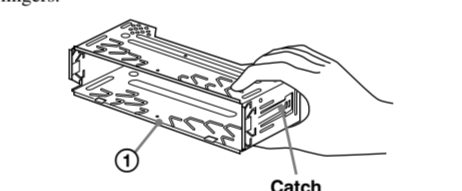

Note Before installing, make sure that the catches on both sides of the bracket (1) are bent inwards 2 mm (7/16 in). If the catches are straight or bent outwards, the unit will not be installed securely and may spring out.

Connection diagram

Warning If you have a power antenna (aerial) without a relay box, connecting this unit with the supplied power supply lead (2) may damage the antenna (aerial).

Notes on the control and power supply leads
 • The power antenna (aerial) control lead (blue) supplies +12 V DC when you turn on the tuner, or when you activate the AF (Alternative Frequency) or TA (Traffic Announcement) function.
 • When your car has built-in FM/MW/LW antenna (aerial) in the rear-side glass, connect the power antenna (aerial) control lead (blue) or the accessory power supply lead (red) to the power terminal of the existing antenna (aerial) booster. For details, consult your dealer.
 • A power antenna (aerial) without a relay box cannot be used with this unit.

Memory hold connection When the yellow power supply lead is connected, power will always be supplied to the memory circuit even when the ignition switch is turned off.

Notes on speaker connection
 • Before connecting the speakers, turn the unit off.
 • Use speakers with an impedance of 4 to 8 Ohms, and with adequate power handling capacities to avoid its damage.
 • Do not connect the speaker terminals to the car chassis, or connect the terminals of the right speakers with those of the left speaker.
 • Do not connect the ground (earth) lead of this unit to the negative (-) terminal of the speaker.
 • Do not attempt to connect the speakers in parallel.
 • Connect only passive speakers. Connecting active speakers (with built-in amplifiers) to the speaker terminals may damage the unit.
 • To avoid a malfunction, do not use the built-in speaker leads installed in your car if the unit shares a common negative (-) lead for the right and left speakers.
 • Do not connect the unit's speaker leads to each other.

Note on connection If speaker is not connected correctly, "FAILURE" appears in the display. In this case, make sure the speaker is connected correctly.

Warnhinweise

- Dieses Gerät ist ausschließlich für den Betrieb bei 12 V Gleichstrom (negative Erdung) bestimmt.
- Achten Sie darauf, dass die Kabel nicht unter einer Schraube oder zwischen beweglichen Teilen wie z. B. in einer Sitzschiene eingeklemmt werden.
- Schalten Sie, bevor Sie irgendwelche Anschlüsse vornehmen, die Zündung des Fahrzeugs aus, um Kurzschlüsse zu vermeiden.
- Verbinden Sie das Stromversorgungskabel (2) mit dem Gerät und den Lautsprechern, bevor Sie es mit dem Hilfsstromanschluss verbinden.
- Schließen Sie alle Erdungskabel an einen gemeinsamen Massepunkt an.
- Aus Sicherheitsgründen müssen alle losen, nicht angeschlossenen Drähte mit Isolierband isoliert werden.

Hinweise zur Stromversorgungsleitung (gelb)
 • Wenn Sie dieses Gerät zusammen mit anderen Stereokomponenten anschließen, muss der Autostromkreis, an den die Geräte angeschlossen sind, eine höhere Leistung aufweisen als die Summe der Sicherungen der einzelnen Komponenten.
 • Wenn kein Autostromkreis eine so hohe Leistung aufweist, schließen Sie das Gerät direkt an die Batterie an.

Teilliste

- Die Nummern in der Liste sind dieselben wie im Erläuterungstext.
- Die Halterung (1) und die Schutzumrandung (2) werden vor dem Ausliefern am Gerät angebracht.
- Das Gerät montieren, nehmen Sie die Halterung (1) und die Schutzumrandung (2) mithilfe der Löseschlüssel (3) bitte vom Gerät ab. Einzelheiten dazu finden Sie unter "Abnehmen der Schutzumrandung und der Halterung (1)" auf der Rückseite dieses Blattes.
- Behalten Sie die Löseschlüssel (3) für den späteren Gebrauch auf. Sie werden z. B. benötigt, wenn Sie das Gerät aus dem Fahrzeug ausbauen wollen.

Vorsicht Sehen Sie beim Umgang mit der Halterung (1) vorsichtig, damit Sie sich nicht die Hände verletzen.

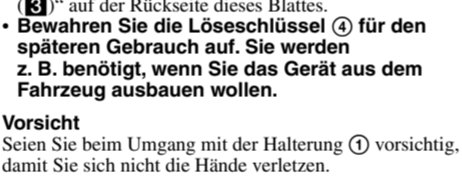

Note Before installing, make sure that the catches on both sides of the bracket (1) are bent inwards 2 mm (7/16 in). If the catches are straight or bent outwards, the unit will not be installed securely and may spring out.

Connection diagram

Warning If you have a power antenna (aerial) without a relay box, connecting this unit with the supplied power supply lead (2) may damage the antenna (aerial).

Notes on the control and power supply leads
 • The power antenna (aerial) control lead (blue) supplies +12 V DC when you turn on the tuner, or when you activate the AF (Alternative Frequency) or TA (Traffic Announcement) function.
 • When your car has built-in FM/MW/LW antenna (aerial) in the rear-side glass, connect the power antenna (aerial) control lead (blue) or the accessory power supply lead (red) to the power terminal of the existing antenna (aerial) booster. For details, consult your dealer.
 • A power antenna (aerial) without a relay box cannot be used with this unit.

Memory hold connection When the yellow power supply lead is connected, power will always be supplied to the memory circuit even when the ignition switch is turned off.

Notes on speaker connection
 • Before connecting the speakers, turn the unit off.
 • Use speakers with an impedance of 4 to 8 Ohms, and with adequate power handling capacities to avoid its damage.
 • Do not connect the speaker terminals to the car chassis, or connect the terminals of the right speakers with those of the left speaker.
 • Do not connect the ground (earth) lead of this unit to the negative (-) terminal of the speaker.
 • Do not attempt to connect the speakers in parallel.
 • Connect only passive speakers. Connecting active speakers (with built-in amplifiers) to the speaker terminals may damage the unit.
 • To avoid a malfunction, do not use the built-in speaker leads installed in your car if the unit shares a common negative (-) lead for the right and left speakers.
 • Do not connect the unit's speaker leads to each other.

Note on connection If speaker is not connected correctly, "FAILURE" appears in the display. In this case, make sure the speaker is connected correctly.

Précautions

- Cet appareil est conçu pour fonctionner uniquement sur un courant continu de 12 V avec masse négative.
- Évitez de coincer les câbles sous des vis ou dans des pièces mobiles (par exemple, armature de siège).
- Avant d'effectuer des raccordements, éteignez le moteur pour éviter les courts-circuits.
- Branchez le câble d'alimentation (2) sur l'appareil et les haut-parleurs avant de le brancher sur le connecteur d'alimentation auxiliaire.
- Rassemblez tous les câbles de mise à la masse en un point de masse commun.
- Veillez à isoler tout câble ou câble non connecté avec du ruban isolant.

Remarques sur le câble d'alimentation (jaune)
 • Lorsque cet appareil est raccordé à d'autres équipements stéréo, la valeur nominale des circuits du véhicule raccordés doit être supérieure à la somme des fusibles de chaque élément.
- Si aucun circuit de la voiture n'est assez puissant, raccordez directement l'appareil à la batterie.

Liste des pièces

- Les numéros de la liste correspondent à ceux des instructions.
- Le support (1) et le tour de protection (2) sont fixés à l'appareil au usine. Avant le montage de l'appareil, utilisez les clés de déblocage (3) pour détacher le support (1) et le tour de protection (2) de l'appareil.
- Pour de plus amples informations, reportez-vous à la section « Retrait du tour de protection et du support (3) » au verso de la feuille.
- Conservez les clés de déblocage (3) pour une utilisation ultérieure car vous en aurez également besoin pour retirer l'appareil de votre véhicule.

Avertissement Manipulez le support (1) avec soin pour éviter de vous blesser aux doigts.



Note Before installing, make sure that the catches on both sides of the bracket (1) are bent inwards 2 mm (7/16 in). If the catches are straight or bent outwards, the unit will not be installed securely and may spring out.

Schémas de raccordement

Warning If you have a power antenna (aerial) without a relay box, connecting this unit with the supplied power supply lead (2) may damage the antenna (aerial).

Notes on the control and power supply leads
 • The power antenna (aerial) control lead (blue) supplies +12 V DC when you turn on the tuner, or when you activate the AF (Alternative Frequency) or TA (Traffic Announcement) function.
 • When your car has built-in FM/MW/LW antenna (aerial) in the rear-side glass, connect the power antenna (aerial) control lead (blue) or the accessory power supply lead (red) to the power terminal of the existing antenna (aerial) booster. For details, consult your dealer.
 • A power antenna (aerial) without a relay box cannot be used with this unit.

Memory hold connection When the yellow power supply lead is connected, power will always be supplied to the memory circuit even when the ignition switch is turned off.

Notes on speaker connection
 • Before connecting the speakers, turn the unit off.
 • Use speakers with an impedance of 4 to 8 Ohms, and with adequate power handling capacities to avoid its damage.
 • Do not connect the speaker terminals to the car chassis, or connect the terminals of the right speakers with those of the left speaker.
 • Do not connect the ground (earth) lead of this unit to the negative (-) terminal of the speaker.
 • Do not attempt to connect the speakers in parallel.
 • Connect only passive speakers. Connecting active speakers (with built-in amplifiers) to the speaker terminals may damage the unit.
 • To avoid a malfunction, do not use the built-in speaker leads installed in your car if the unit shares a common negative (-) lead for the right and left speakers.
 • Do not connect the unit's speaker leads to each other.

Note on connection If speaker is not connected correctly, "FAILURE" appears in the display. In this case, make sure the speaker is connected correctly.

Attenzione

- Questo apparecchio è stato progettato per l'uso solo a 12 V CC con massa negativa.
- Evitare che i cavi rimangano bloccati da una vite o incastrati nelle parti mobili (ad esempio nelle guide scorrevoli dei sedili).
- Prima di effettuare i collegamenti, spegnere il motore dell'automobile onde evitare di causare cortocircuiti.
- Collegare il cavo di alimentazione (2) all'apparecchio e ai diffusori prima di collegarlo al connettore di alimentazione ausiliaria.
- Portare tutti i cavi di messa a terra a un punto di massa comune.
- Veiligheidsmaatregelen: isoleer alle losse en niet aangesloten kabels met isolatietape.

Note sul cavo di alimentazione (giallo)
 • Se questo apparecchio viene collegato in combinazione con altri componenti stereo, la potenza nominale dei circuiti dell'automobile deve essere superiore a quella prodotta dalla somma dei fusibili di ciascun componente.
- Se la potenza nominale dei circuiti dell'automobile non è sufficiente, collegare l'apparecchio direttamente alla batteria.

Elenco dei componenti

- I numeri nella lista corrispondono a quelli riportati nelle istruzioni.
- La staffa (1) e la cornice protettiva (2) vengono applicati all'unità in fabbrica. Prima di installare l'unità, utilizzare le chiavi di rilascio (3) per rimuovere la staffa (1) e la cornice protettiva (2) dall'apparecchio. Per ulteriori informazioni, vedere "Rimozione della staffa e della cornice protettiva (2)" sul lato opposto del foglio.
- Conservare le chiavi di rilascio (3) per un uso futuro in quanto sono necessarie per rimuovere l'unità dall'auto.

Attenzione Manipolare la staffa (1) con cautela per evitare di ferirsi le mani.



Note Before installing, make sure that the catches on both sides of the bracket (1) are bent inwards 2 mm (7/16 in). If the catches are straight or bent outwards, the unit will not be installed securely and may spring out.

Schema di collegamento

Warning If you have a power antenna (aerial) without a relay box, connecting this unit with the supplied power supply lead (2) may damage the antenna (aerial).

Notes on the control and power supply leads
 • The power antenna (aerial) control lead (blue) supplies +12 V DC when you turn on the tuner, or when you activate the AF (Alternative Frequency) or TA (Traffic Announcement) function.
 • When your car has built-in FM/MW/LW antenna (aerial) in the rear-side glass, connect the power antenna (aerial) control lead (blue) or the accessory power supply lead (red) to the power terminal of the existing antenna (aerial) booster. For details, consult your dealer.
 • A power antenna (aerial) without a relay box cannot be used with this unit.

Memory hold connection When the yellow power supply lead is connected, power will always be supplied to the memory circuit even when the ignition switch is turned off.

Notes on speaker connection
 • Before connecting the speakers, turn the unit off.
 • Use speakers with an impedance of 4 to 8 Ohms, and with adequate power handling capacities to avoid its damage.
 • Do not connect the speaker terminals to the car chassis, or connect the terminals of the right speakers with those of the left speaker.
 • Do not connect the ground (earth) lead of this unit to the negative (-) terminal of the speaker.
 • Do not attempt to connect the speakers in parallel.
 • Connect only passive speakers. Connecting active speakers (with built-in amplifiers) to the speaker terminals may damage the unit.
 • To avoid a malfunction, do not use the built-in speaker leads installed in your car if the unit shares a common negative (-) lead for the right and left speakers.
 • Do not connect the unit's speaker leads to each other.

Note on connection If speaker is not connected correctly, "FAILURE" appears in the display. In this case, make sure the speaker is connected correctly.

Let op

- Dit apparaat is ontworpen voor gebruik op een auto-cavo van 12 V gelijkstroom, negatieve aarde.
- Zorg ervoor dat de draden niet onder een schroef of tussen bewegende onderdelen (bv. zetelrill) terecht komen.
- Voordat u de aansluitingen maakt, moet u het contact uitzetten om kortsluiting te vermijden.
- Sluit de voedingskabel (2) aan op het apparaat en de luidsprekers voordat u het aansluit op de hulpvoedingsaansluiting.
- Sluit alle aardingskabels op een gemeenschappelijk aardpunt aan.
- Voorzie niet aangesloten kabels om veiligheidsredenen altijd van isolatietape.

Opmmerkingen bij de voedingskabel (geel)
 • Wanneer dit apparaat aansluit samen met andere componenten, moet het vermogen van de aangesloten auto-stroomkring groter zijn dan de som van de zekeringen van elke component afzonderlijk.
- Wanneer het vermogen ontoereikend is, moet u het apparaat rechtstreeks aansluiten op de accu.

Onderdelenlijst

- De nummers in de afbeelding verwijzen naar die in de montage-aanwijzingen.
- De beugel (1) en de beschermende rand (2) worden bevestigd op het apparaat voordat dit wordt verzonden. Voordat u het apparaat plaatst, moet u de ontgrendelingsleutels (3) gebruiken om de beugel (1) en de beschermende rand (2) te verwijderen van het apparaat. Zie "De beschermende rand en de beugel verwijderen (3)" aan de achterzijde van dit vel voor meer informatie.
- Bewaar de ontgrendelingsleutels (3) voor toekomstig gebruik omdat u deze ook nodig hebt om het apparaat uit de auto te verwijderen.

Let op Houd de beugel (1) voorzichtig vast zodat u uw vingers niet verwondt.



Note Before installing, make sure that the catches on both sides of the bracket (1) are bent inwards 2 mm (7/16 in). If the catches are straight or bent outwards, the unit will not be installed securely and may spring out.

Aansluitschema

Warning If you have a power antenna (aerial) without a relay box, connecting this unit with the supplied power supply lead (2) may damage the antenna (aerial).

Notes on the control and power supply leads
 • The power antenna (aerial) control lead (blue) supplies +12 V DC when you turn on the tuner, or when you activate the AF (Alternative Frequency) or TA (Traffic Announcement) function.
 • When your car has built-in FM/MW/LW antenna (aerial) in the rear-side glass, connect the power antenna (aerial) control lead (blue) or the accessory power supply lead (red) to the power terminal of the existing antenna (aerial) booster. For details, consult your dealer.
 • A power antenna (aerial) without a relay box cannot be used with this unit.

Memory hold connection When the yellow power supply lead is connected, power will always be supplied to the memory circuit even when the ignition switch is turned off.

Notes on speaker connection
 • Before connecting the speakers, turn the unit off.
 • Use speakers with an impedance of 4 to 8 Ohms, and with adequate power handling capacities to avoid its damage.
 • Do not connect the speaker terminals to the car chassis, or connect the terminals of the right speakers with those of the left speaker.
 • Do not connect the ground (earth) lead of this unit to the negative (-) terminal of the speaker.
 • Do not attempt to connect the speakers in parallel.
 • Connect only passive speakers. Connecting active speakers (with built-in amplifiers) to the speaker terminals may damage the unit.
 • To avoid a malfunction, do not use the built-in speaker leads installed in your car if the unit shares a common negative (-) lead for the right and left speakers.
 • Do not connect the unit's speaker leads to each other.

Note on connection If speaker is not connected correctly, "FAILURE" appears in the display. In this case, make sure the speaker is connected correctly.

Waarschuwing

- Indien u een elektrische antenne heeft zonder relaiskast, kan het aansluiten van de bijgeleverde voedingskabel (2) de antenne beschadigen.
- Opmmerkingen over de bedrading en de voedingskabel
 • De bedrading van de elektrische antenne (blauw) leverbaar met de functie AF (alternatieve frequentie) of TA (verkeersaanwijzing) wordt actief.
- Wanneer uw auto is uitgerust met een FM/MW/LW-antenne in de achterruitvoorzicht, moet u de bedrading van de elektrische antenne (blauw) of de voedingskabel van de accessoires (rood) aansluiten op de voedingsgang van de bestaande antenneversterker. Raadpleeg uw dealer voor meer details.
- Met dit apparaat is het niet mogelijk een elektrische antenne zonder relaiskast te gebruiken.

Instandhouden van het geheugen Zolang de gele voedingskabel is aangesloten, blijft de stroomvoorziening van het geheugen intact, ook wanneer de contactschakelaar van de auto wordt uitschakeld.

Opmmerkingen betreffende het aansluiten van de luidsprekers
 • Zorg dat het apparaat is uitgeschakeld, alvorens de luidsprekers aan te sluiten.
- Gebruik luidsprekers met een impedantie van 4 tot 8 Ohm en niet op dat die het vermogen van de versterker kunnen verwerken. Als dit wordt verzuimd, kunnen de luidsprekers ernstig beschadigd raken.
- Verbind in geen geval de aansluitingen van de luidsprekers met het chassis van de auto en sluit de aansluitingen van de rechter- en linkerluidspreker niet op elkaar aan.
- Verbind de aarddraad van dit apparaat niet met de negatieve (-) aansluiting van de luidsprekers.
- Probeer nooit de luidsprekers parallel aan te sluiten.
- Sluit geen actieve luidsprekers (met ingebouwde versterkers) aan op de luidspreker-aansluiting van dit apparaat. Dit zal leiden tot beschadiging van de actieve luidsprekers. Sluit dus altijd uitsluitend luidsprekers zonder ingebouwde versterker aan.
- Om defecten te vermijden mag u de bestaande luidsprekerdraden in uw auto niet gebruiken wanneer er een gemeenschappelijke negatieve (-) draad is voor de rechter- en linkerluidspreker.
- Verbind de luidsprekerdraden niet met elkaar.

Opmmerking over aansluiten Als de luidspreker niet goed is aangesloten, wordt "FAILURE" in het display weergegeven. In dit geval moet u zorgen dat de luidspreker correct is aangesloten.

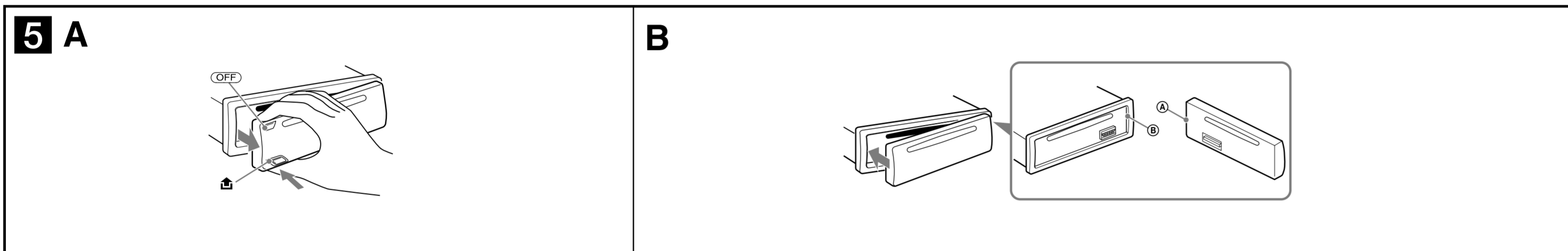
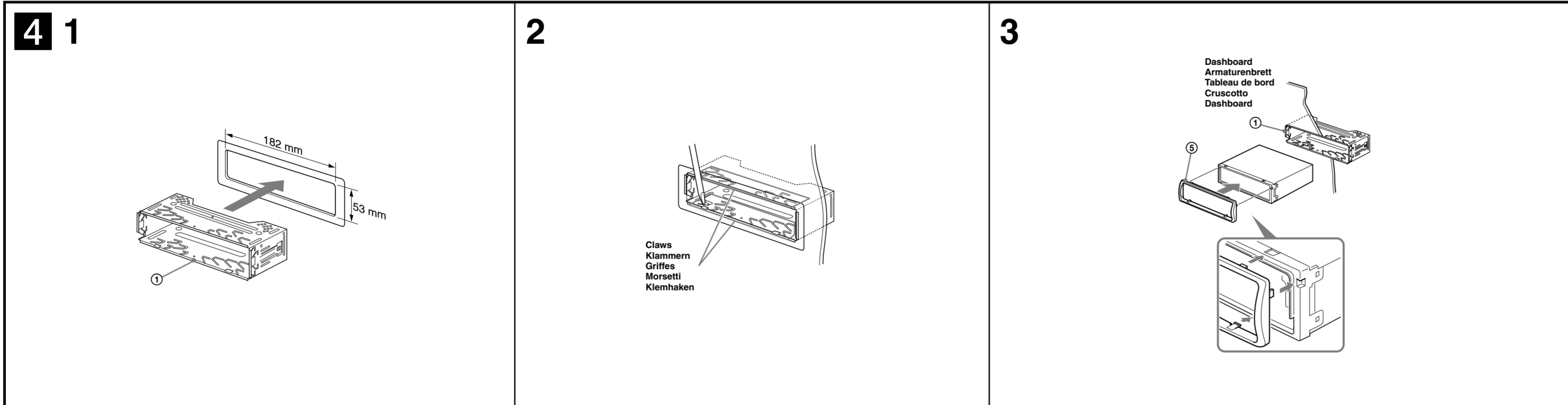
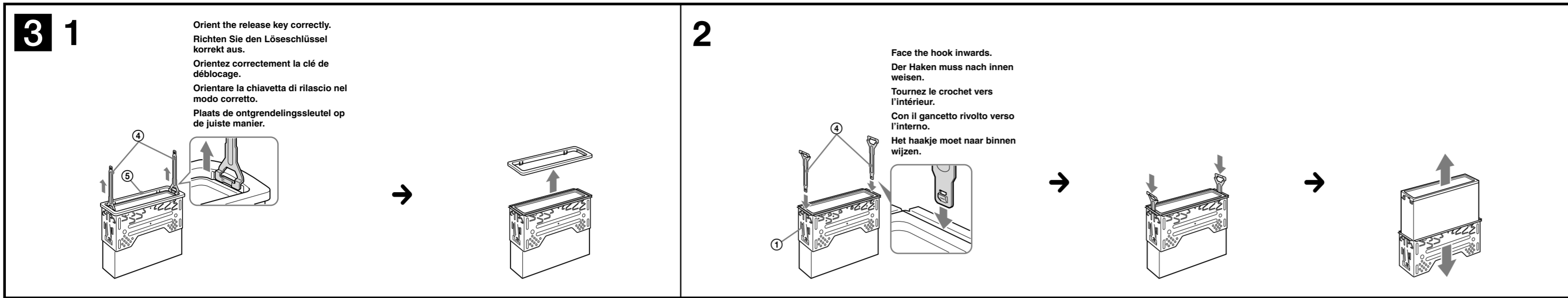

Precautions

- Choose the installation location carefully so that the unit will not interfere with normal driving operations.
- Avoid installing the unit in areas subject to dust, dirt, excessive vibration, or high temperature, such as in direct sunlight or near heater ducts.
- Use only the supplied mounting hardware for a safe and secure installation.

Mounting angle adjustment

Adjust the mounting angle to less than 45°.

Removing the protection collar and the bracket

Before installing the unit, remove the protection collar (3) and the bracket (4) from the unit.

- 1 Remove the protection collar (3).**
 - Engage the release keys (2) together with the protection collar (3).
 - Pull out the release keys (2) to remove the protection collar (3).
- 2 Remove the bracket (4).**
 - Insert both release keys (2) together between the unit and the bracket (4) until they click.
 - Pull down the bracket (4), then pull up the unit to separate.

Mounting example

Installation in the dashboard

- Notes**
- Bind these claws outward for a tight fit, if necessary (1-2).
 - Make sure that the 4 catches on the protection collar (3) are properly engaged in the slots of the unit (1-3).

How to detach and attach the front panel

Before installing the unit, detach the front panel.

5-A To detach

Before detaching the front panel, be sure to press (OFF). Press (A), and pull it off towards you.

5-B To attach

Engage part (B) of the front panel with part (A) of the unit, as illustrated, and push the left side into position until it clicks.

Warning if your car's ignition has no ACC position

Be sure to set the Auto Off function. For details, see the supplied Operating Instructions. The unit will shut off completely and automatically in the set time after the unit is turned off, which prevents battery drain. If you do not set the Auto Off function, press and hold (OFF) until the display disappears each time you turn the ignition off.

Sicherheitshinweise

- Wählen Sie den Einbaort sorgfältig so aus, dass das Gerät beim Fahren nicht hinderlich ist.
- Basen Sie das Gerät so ein, dass es keinen hohen Temperaturen (keinem direkten Sonnenlicht, keiner Warmluft von der Heizung), keinem Staub, keinem Schmutz und keinen starken Vibrationen ausgesetzt ist.
- Für eine sichere Befestigung verwenden Sie stets die mitgelieferten Montageteile.

Hinweis zum Montagewinkel

Das Gerät sollte in einem Winkel von weniger als 45° montiert werden.

Abnehmen der Schutzumrandung und der Halterung

Nehmen Sie vor dem Installieren des Geräts die Schutzumrandung (3) und die Halterung (4) vom Gerät ab.

- 1 Entfernen Sie die Schutzumrandung (3).**
 - Setzen Sie beide Löseschlüssel (2) an der Schutzumrandung (3) an.
 - Ziehen Sie die Schutzumrandung (3) mithilfe der Löseschlüssel (2) heraus.
- 2 Entfernen Sie die Halterung (4).**
 - Führen Sie beide Löseschlüssel (2) zwischen dem Gerät und der Halterung (4) ein, bis sie mit einem Klicken einrasten.
 - Ziehen Sie die Halterung (4) nach unten und das Gerät nach oben, um die beiden zu trennen.

Montagebeispiel

Installation im Armaturenbrett

- Hinweise**
- Falls erforderlich, biegen Sie diese Klammern für einen sicheren Halt nach außen (1-2).
 - Achten Sie darauf, die 4 Verriegelungen an der Schutzumrandung (3) korrekt in die Aussparungen am Gerät einzusetzen (1-3).

Abnehmen und Anbringen der Frontplatte

Nehmen Sie die Frontplatte vor dem Einbau des Geräts ab.

5-A Abnehmen

Schalten Sie das Gerät vor dem Abnehmen der Frontplatte unbedingt mit (OFF) aus. Drücken Sie (A) und ziehen Sie sie auf sich zu heraus.

5-B Anbringen

Setzen Sie Teil (B) der Frontplatte wie in der Abbildung dargestellt an Teil (A) des Geräts an und drücken Sie die linke Seite der Frontplatte an, bis sie mit einem Klicken einrastet.

Warnhinweis, wenn die Zündung Ihres Fahrzeugs nicht über eine Zubehörposition (ACC oder I) verfügt

Aktivieren Sie unbedingt die Abschaltautomatik. Näheres dazu finden Sie in der mitgelieferten Bedienungsanleitung. Nach dem Ausschalten wird das Gerät dann nach der voreingestellten Zeit automatisch vollständig abgeschaltet, so dass der Autobatterie kein Strom mehr entzogen wird. Wenn Sie die Abschaltautomatik nicht aktivieren, müssen Sie jedes Mal, wenn Sie die Zündung ausschalten, die Taste (OFF) gedrückt halten, bis die Anzeige ausgeblendet wird.

Précautions

- Choisir soigneusement l'emplacement de l'installation afin que l'appareil ne gêne pas la conduite normale du véhicule.
- Éviter d'installer l'appareil dans un endroit exposé à la poussière, de la saleté, des vibrations violentes ou à des températures élevées, comme en plein soleil ou à proximité d'un conduit de chauffage.
- Pour garantir un montage sûr, n'utiliser que le matériel fourni.

Réglage de l'angle de montage

Ajuster l'inclinaison à un angle inférieur à 45°.

Retrait du tour de protection et du support

Avant d'installer l'appareil, retirez le tour de protection (3) et le support (4) de l'appareil.

- 1 Enlevez le tour de protection (3).**
 - Retirez les clés de déblocage (2) simultanément dans le tour de protection (3).
 - Tirez sur la clé de déblocage (2) pour retirer le tour de protection (3).
- 2 Retirez le support (4).**
 - Insérez les deux clés de déblocage (2) simultanément entre l'appareil et le support (4) jusqu'au déclic indiquant qu'elles sont en place.
 - Tirez le support (4) vers le bas, puis tirez l'appareil vers le haut pour les séparer.

Exemple de montage

Installation dans le tableau de bord

- Remarques**
- Pliez ces griffes pour assurer une prise correcte si nécessaire (1-2).
 - Assurez-vous que les 4 boquets du tour de protection (3) sont correctement insérés dans les fentes de l'appareil (1-3).

Retrait et pose de la façade

Avant d'installer l'appareil, retirez la façade.

5-A Pour la retirer

Avant de retirer la façade, n'oubliez pas d'appuyer sur (OFF). Appuyez ensuite sur (A), puis faites glisser la façade vers vous.

5-B Pour la fixer

Fixez la partie (B) de la façade sur la partie (A) de l'appareil, comme indiqué sur l'illustration, puis appuyez sur le côté gauche jusqu'au déclic.

Avertissement au cas où le contact de votre voiture ne dispose pas d'une position ACC

Veillez à régler la fonction de mise hors tension automatique. Pour obtenir davantage d'informations, reportez-vous au mode d'emploi fourni. L'appareil s'éteint complètement et automatiquement après le laps de temps choisi une fois l'appareil mis hors tension afin d'éviter que la batterie ne se décharge. Si vous ne réglez pas la fonction de mise hors tension automatique, appuyez sur la touche (OFF) et maintenez-la enfoncée jusqu'à ce que l'affichage disparaisse à chaque fois que vous coupez le contact.

Precauzioni

- Scegliere con attenzione la posizione per l'installazione in modo che l'apparecchio non interferisca con le operazioni di guida del conducente.
- Evitare di installare l'apparecchio dove sia soggetto ad alte temperature, come alla luce solare diretta o al getto di aria calda dell'impianto di riscaldamento, o dove possa essere soggetto a polvere, sporco e vibrazioni eccessive.
- Usare solo il materiale di montaggio in dotazione per un'installazione stabile e sicura.

Regolazione dell'angolo di montaggio

Regolare l'angolo di montaggio in modo che sia inferiore a 45°.

Rimozione della staffa e della cornice protettiva

Prima di installare l'apparecchio, rimuovere la cornice protettiva (3) e la staffa (4) dall'apparecchio.

- 1 Rimuovere la cornice protettiva (3).**
 - Inserire le chavette di rilascio (2) nella cornice protettiva (3).
 - Per rimuovere la cornice protettiva (3) estrarre le chavette di rilascio (2).
- 2 Rimuovere la staffa (4).**
 - Inserire contemporaneamente entrambe le chavette di rilascio (2) tra l'apparecchio e la staffa (4) fino a che non scattano in posizione.
 - Estrarre la staffa (4), quindi sollevare l'apparecchio per rimuoverlo.

Esempio di montaggio

Installazione nel cruscotto

- Note**
- Piegare verso l'esterno questi morsetti per un'installazione più sicura, se necessario (1-2).
 - Assicurarsi che i 4 fermi sulla cornice protettiva (3) siano correttamente inseriti negli alloggiamenti dell'apparecchio (1-3).

Come rimuovere e reinserire il pannello anteriore

Prima di installare l'apparecchio rimuovere il pannello anteriore.

5-A Per rimuoverlo

Prima di rimuovere il pannello anteriore, premere (OFF). Premere (A), quindi tirare verso di sé il pannello anteriore.

5-B Per reinserirlo

Applicare la parte (B) del pannello anteriore alla parte (A) dell'apparecchio come mostrato nell'illustrazione e premere il lato sinistro fino a sentire uno scatto.

Avvertenza relativa all'installazione su un'auto sprovvista della posizione ACC (accessoria) sul blocchetto di accensione

Accertarsi di impostare la funzione di spegnimento automatico. Per ulteriori informazioni, fare riferimento alle istruzioni per l'uso in dotazione. L'apparecchio si spegne completamente e automaticamente all'ora impostata dopo che è stato disattivato, onde evitare che la batteria si scarichi. Se la funzione di spegnimento automatico non è stata impostata, ogni volta che il motore viene spento tenere premuto (OFF) finché il display non viene disattivato.

Power connection diagram

Auxiliary power connector may vary depending on the car. Check your car's auxiliary power connector diagram to make sure the connections match correctly. There are three basic types (illustrated below). You may need to switch the positions of the red and yellow leads in the car stereo's power supply lead. After matching the connections and switched power supply leads correctly, connect the unit to the car's power supply. If you have any questions and problems connecting your unit that are not covered in this manual, please consult the car dealer.

Diagramma dei collegamenti di alimentazione

Il connettore di alimentazione ausiliaria può variare a seconda della macchina. Controllare il diagramma del connettore di alimentazione ausiliaria della macchina per essere sicuri che i collegamenti corrispondano correttamente. Vi sono tre tipi di base (illustrazione sotto). Potrà essere necessario cambiare le posizioni dei fili rosso e giallo nel cavo di alimentazione dello stereo della macchina. Dopo aver fatto corrispondere i collegamenti e aver commutato i cavi di alimentazione, collegare l'apparecchio all'alimentazione della macchina. Se si hanno domande o se sorgono problemi che non sono stati trattati nel manuale nel collegare l'apparecchio, contattare l'autocessionario.

Stromanschlussdiagramm

Der Hilfsstromanschluss kann je nach Fahrzeugtyp unterschiedlich sein. Sehen Sie im Hilfsstromanschlussdiagramm für Ihr Fahrzeug nach, wie die Verbindung ordnungsgemäß vorgenommen werden muss. Es gibt, wie unten abgebildet, drei grundlegende Typen. Sie müssen möglicherweise die rote und gelbe Leitung des Stromversorgungs Kabels der Autostereoanlage vertauschen. Stellen Sie die Anschlüsse her, schließen Sie die geschalteten Stromversorgungsleitungen richtig an und verbinden Sie dann das Gerät mit der Stromversorgung Ihres Fahrzeugs. Wenn beim Anschließen des Geräts Fragen oder Probleme auftreten, die in dieser Bedienungsanleitung nicht erläutert werden, wenden Sie sich bitte an den Autobändler.

Voedingsaansluitschema

De hulpvoedingsaansluiting kan verschillen afhankelijk van de auto. Controleer het hulpvoedingsaansluitschema dat bij dit apparaat wordt geleverd om te zien of de aansluitingen kloppen. Er zijn drie basistypen (zie afbeelding hieronder). Het is mogelijk dat u de posities van de rode en gele kabels in de voedingskabel van het car audiosysteem moet omwisselen. Als de aansluitingen en geschakelde voedingskabels kloppen, sluit u het apparaat aan op de voeding van de auto. Indien u nog vragen of problemen hebt in verband met het aansluiten van het apparaat die niet in deze handleiding vermeld staan, raadpleeg dan de autodealer.

Schéma de raccordement d'alimentation

Le connecteur d'alimentation auxiliaire peut varier suivant le type de voiture. Vérifiez le schéma du connecteur d'alimentation auxiliaire de votre voiture pour vous assurer que les connexions correspondent. Il en existe trois types de base (illustrés ci-dessous). Il se peut que vous deviez commuter la position du fil rouge et jaune du câble d'alimentation de l'autoradio. Après avoir établi les connexions et commuté correctement les câbles d'alimentation, raccordez l'appareil à l'alimentation de la voiture. Si vous avez des questions ou des difficultés à propos de cet appareil qui ne sont pas abordées dans le présent mode d'emploi, consultez votre concessionnaire automobile.

Auxiliary power connector
Hilfsstromanschluss
Conneteur d'alimentation auxiliaire
Connetore di alimentazione ausiliaria
Hulpvoedingsaansluiting

