

Lens for Digital Single Lens Reflex Camera

Operating Instructions

300mm F2.8 G

SAL300F28G

©2006 Sony Corporation Printed in Japan



<http://www.sony.net/>



Printed on 70% or more recycled paper using VOC (Volatile Organic Compound)-free vegetable oil based ink.

This lens is designed for Sony α cameras.

WARNING

To reduce fire or shock hazard, do not expose the unit to rain or moisture. Do not directly look at the sun through this lens. Doing so might harm your eyes or cause loss of eyesight. Keep the lens out of reach of small children. There is danger of accident or injury.



Disposal of Old Electrical & Electronic Equipment (Applicable in the European Union and other European countries with separate collection systems)

This symbol on the product or on its packaging indicates that this product shall not be treated as household waste. Instead it shall be handed over to the applicable collection point for the recycling of electrical and electronic equipment. By ensuring this product is disposed of correctly, you will help prevent potential negative consequences for the environment and human health, which could otherwise be caused by inappropriate waste handling of this product. The recycling of materials will help to conserve natural resources. For more detailed information about recycling of this product, please contact your local Civic Office, your household waste disposal service or the shop where you purchased the product.

For the customers in the U.S.A.

THIS DEVICE COMPLIES WITH PART 15 OF THE FCC RULES. OPERATION IS SUBJECT TO THE FOLLOWING TWO CONDITIONS:

(1) THIS DEVICE MAY NOT CAUSE HARMFUL INTERFERENCE, AND (2) THIS DEVICE MUST ACCEPT ANY INTERFERENCE RECEIVED, INCLUDING INTERFERENCE THAT MAY CAUSE UNDESIRE OPERATION.

CAUTION

You are cautioned that any changes or modifications not expressly approved in this manual could void your authority to operate this equipment.

NOTE:

This equipment has been tested and found to comply with the limits for a Class B digital device, pursuant to Part 15 of the FCC Rules. These limits are designed to provide reasonable protection against harmful interference in a residential installation. This equipment generates, uses, and can radiate radio frequency energy and, if not installed and used in accordance with the instructions, may cause harmful interference to radio communications.

However, there is no guarantee that interference will not occur in a particular installation. If this equipment does cause harmful interference to radio or television reception, which can be determined by turning the equipment off and on, the user is encouraged to try to correct the interference by one or more of the following measures:

- Reorient or relocate the receiving antenna.
- Increase the separation between the equipment and receiver.
- Connect the equipment into an outlet on a circuit different from that to which the receiver is connected.
- Consult the dealer or an experienced radio/TV technician for help.

For the customers in Canada

This Class B digital apparatus complies with Canadian ICES-003.

Notes on use

- Do not leave the lens in direct sunlight. If sunlight is focused onto a nearby object, it may cause a fire. If circumstances necessitate leaving the lens in direct sunlight, be sure to attach the lens cap.
- Be careful not to subject the lens to mechanical shock while attaching it.
- Always place the lens caps on the lens when storing.
- Do not keep the lens in a very humid place for a long period of time to prevent mold.
- Hold both the camera and lens, when you carry the camera with the lens attached.
- Do not touch the lens contacts. If dirt, etc., gets on the lens contacts, it may interfere or prevent the sending and receiving of signals between the lens and the camera, resulting in operational malfunction.

Vignetting

When you use lens, the corners of the screen become darker than the center. To reduce this phenomena (called vignetting), close the aperture by 1 to 2 stops.

Condensation

If your lens is brought directly from a cold place to a warm place, condensation may appear on the lens. To avoid this, place the lens in a plastic bag or something similar. When the air temperature inside the bag reaches the surrounding temperature, take the lens out.

Cleaning the lens

- Do not touch the surface of the lens directly.
- If the lens gets dirty, brush off dust with a lens blower and wipe with a soft, clean cloth (Cleaning Cloth KK-CA (optional) is recommended).
- Do not use any organic solvent, such as thinner or benzene, to clean the lens or the camera cone.

A Names of parts

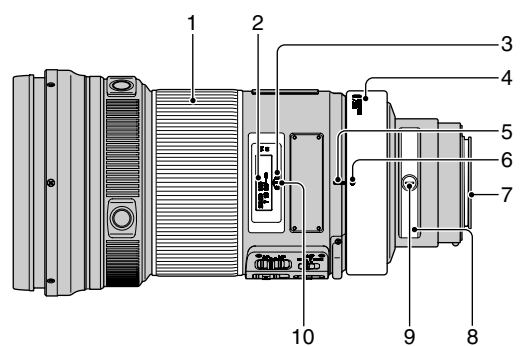

1...Focusing ring 2...Distance scale 3...Depth-of-field scale 4...Collar mounting index (red) 5...Lens index (gray) 6...Collar index (gray) 7...Lens contacts 8...Filter holder 9...Filter-holder lock 10...Distance index

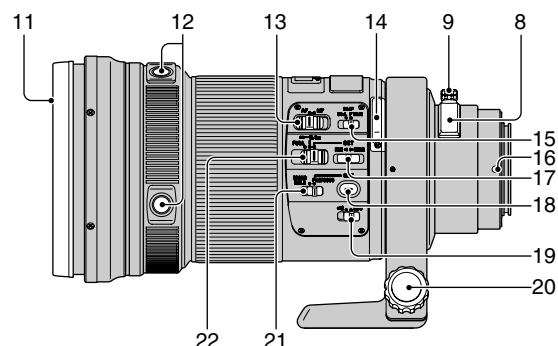

11...Protective element 12...Focus-hold buttons 13...Focus-mode switch 14...Strap eyelet 15...DMF-mode switch 16...Lens mounting index 17...Focus-range setting switch 18...Prefocus set button 19...Audio-signal switch 20...Collar-locking knob 21...Focus-hold/prefocus switch 22...Focus-range limiter

B Attaching/detaching the lens

To attach the lens

- 1 Remove the front and rear lens caps and the camera body cap.

- 2 Align the orange index on the lens barrel with the orange index on the camera (mounting index), then insert the lens into the camera mount and rotate it clockwise until it locks.

- Do not press the lens release button on the camera when mounting the lens.
- Do not mount the lens at an angle.

To remove the lens

While pressing and holding the lens release button on the camera, rotate the lens counterclockwise until it stops, then detach the lens.

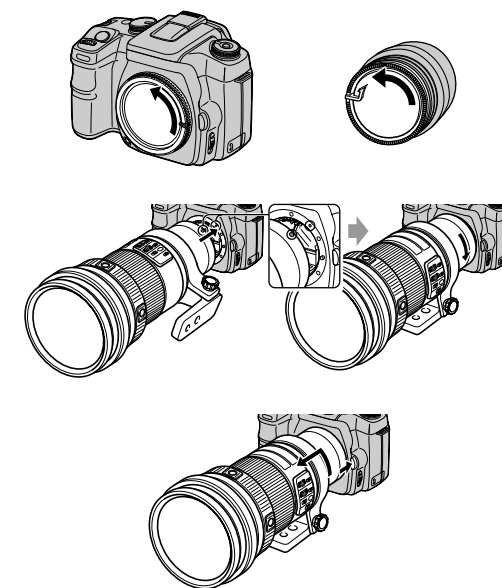

C Attaching a tripod

Attach the tripod to the lens, not to the camera.

To change vertical/horizontal position

Loosen the collar-locking knob on the tripod-mounting collar (1) and rotate the camera either direction. The camera can be quickly switched between vertical and horizontal positions while maintaining stability when using a tripod.

- Gray indexes (collar indexes) are located at 90° intervals on the tripod-mounting collar. Align a gray index on the tripod-mounting collar with the gray index (collar index) on the lens to adjust the camera position precisely (2).
- Tighten the collar-locking knob firmly after the camera position is set.

To detach the tripod-mounting collar

The tripod-mounting collar can be detached.

- 1 Remove the lens from the camera.
 - See "B Attaching/detaching the lens" for details.
- 2 Loosen the collar-locking knob (1).
- 3 Rotate the tripod-mounting collar to align the red index on the tripod-mounting collar (collar mounting index next to SET/RELEASE) with the orange index on the lens (mounting index) (3).
- 4 Move the tripod-mounting collar towards the lens mount and detach the tripod-mounting collar from the lens (4).

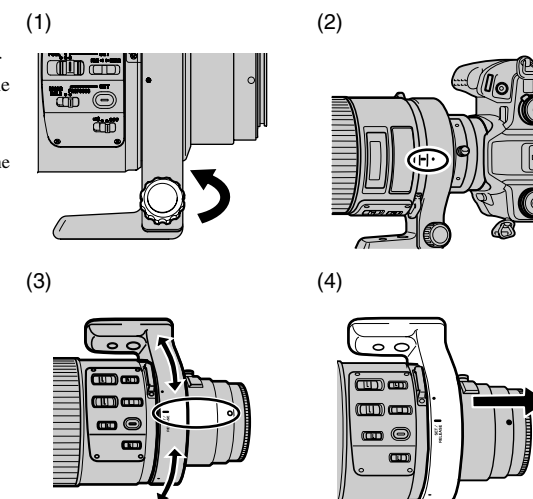

D Attaching the lens hood

It is recommended that you use a lens hood to reduce flare and ensure maximum image quality.

Loosen the locking screw on the lens hood and slip the lens hood over the front of the lens. Check that lens hood is attached properly, and then tighten the screw.

- When using a built-in camera flash, make sure to remove the lens hood to avoid blockage of the flash light.
- When storing, turn the lens hood back over the lens, and tighten the screw to secure the lens hood to the lens.

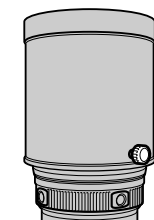

E Attaching the strap

Attach the strap so that the lens can be carried easily. Follow steps (1) and (2) to attach the strap.

- To prevent the lens from dropping, be sure to attach the strap properly so that the strap will not come loose from the lens.

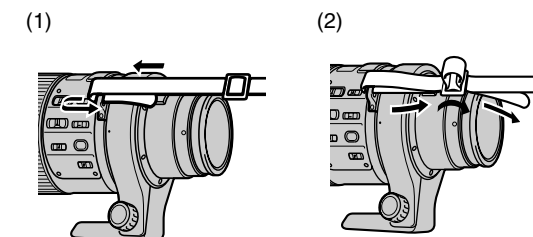

F Focusing

To switch AF (auto focus)/MF (manual focus)

The focus mode can be switched between AF and MF on the lens.

For AF photography, both the camera and lens should be set to AF. For MF photography, either or both the camera or lens should be set to MF.

- The focusing ring can be rotated slightly past the infinity to provide accurate focusing under various operating temperatures. Do not rotate the focusing ring all the way to the end when focusing manually, even at infinity. Look through the viewfinder and set the focus precisely.

To set the focus mode on the lens

Slide the focus-mode switch to the appropriate mode, AF or MF (1).

- Refer to the camera manuals to set the focus mode of the camera.
- In MF, turn the focusing ring to adjust the focus (2) while looking through the viewfinder. The focus signal in the viewfinder indicates the current condition of the focus.

To use a camera equipped with an AF/MF control button

- Press the AF/MF control button to switch AF to MF when both the camera and lens are set to AF.
- Press the AF/MF control button to switch MF to AF when the camera is set to MF and the lens is set to AF.

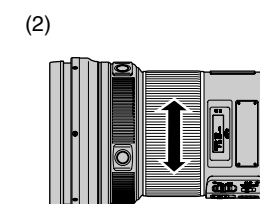
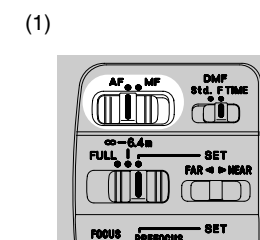

Direct manual focus (DMF)

Even when AF is set, the setting is switched to MF automatically if you rotate the focusing ring while pressing the shutter button halfway. This provides quick fine adjustment of focusing (DMF). Select the mode for correct DMF from the following. Set the DMF-mode switch to whichever you prefer.

Standard DMF (Std.)

Rotate the focusing ring to set correct DMF when the focus is locked in AF-A (automatic auto focus) or AF-S (single-shot auto focus). Using this mode is recommended for normal subjects.

- DMF is not available in AF-C (continuous auto focus), when out of focus, or with continuous advance in AF-A after the second focus is confirmed.

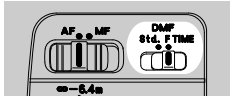

Full-time DMF (F TIME)

In any AF mode (AF-A/S/C), rotate the focusing ring while pressing the shutter button halfway to set correct DMF. This is useful to catch a fast-moving subject.

Depth-of-field scale

When focus is set on a subject, anything at that same distance will appear sharp, and anything within a certain range before and beyond the subject will also appear in focus; this is called depth of field. Depth of field depends on the subject distance and aperture you choose and is indicated by the lines on the depth-of-field scale corresponding to the aperture.

- The depth-of-field scale and depth-of-field table are for 35mm-format cameras. The depth-of-field is shallower when you use Digital Single Lens Reflex Cameras equipped with an APS-C sized image sensor.

Using focus-hold buttons

This lens has 4 focus-hold buttons.

Press the focus-hold button in AF to cancel AF. The focus is fixed and you can release the shutter on the fixed focus. Release the focus-hold button while pressing the shutter button halfway to start AF again.

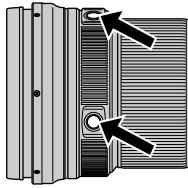

Set the focus-hold/prefocus switch to FOCUS HOLD and press the focus-hold button.

- The function of the focus-hold button can be changed on cameras with custom function capability. Refer to the camera manuals for details.

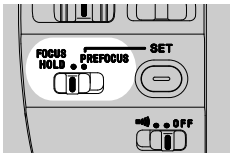

Switching focus range (AF range)

The focus-range limiter enables you to reduce the auto focusing time. This is useful when the subject distance is definite. You can also set the desired focus range and select it.

Slide the focus-range limiter to select the focus range.

- FULL: The focus range is not limited. AF is set to the entire focus range.
- ∞ - 6.4m: AF is set to 6.4 m (21 feet) to infinity.
- SET: AF is set to the appointed focus range, both far and near positions.

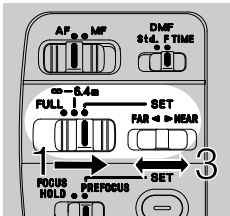

To set the focus range

- Slide the focus-range limiter to SET.
- Focus the lens to the desired far or near distance.
 - The focusing distance can be set in any focus mode: AF, MF or DMF.
 - The far and near focusing distance can be set in either order.
- Slide the focus-range setting switch to FAR or NEAR for the appropriate focus range position (depending on which position you set first).
 - The focus-range setting switch automatically returns to the original position.
 - If the audio-signal switch is on, it beeps when you set the focus range.
 - The focus range to be set is effective until a new focus range is set.

Using prefocus

A specific subject distance can be stored and recalled at any time. With the distance set, this is useful for catching fast-moving subjects, such as a moving train, events at a sports festival, or horse and car races, etc.

To set the subject distance

- Slide the focus-hold/prefocus switch to PREFOCUS.
- Focus the lens on the distance to be set.
 - The focusing distance can be set in any focus mode: AF, MF or DMF.
- Press the prefocus set button to store the subject distance.
 - The stored subject distance is effective until a new subject distance is set.
 - If the audio-signal switch is on, it beeps when you store the subject distance.

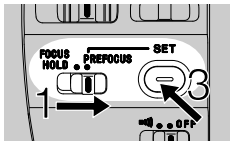

To recall the preset subject distance

- Slide the focus-hold/prefocus switch to PREFOCUS.
 - Set the focus hold button function to "focus hold" for cameras with custom function capability.
- Press the focus-hold button so that the lens will focus to the prefocus position.
 - When AF is set, press and hold the focus-hold button while taking pictures. If the focus-hold button is released, AF will be reactivated and the subject focus distance will be changeable.
 - If the audio-signal switch is on, it beeps when the preset subject distance is recalled.

Using the audio signal

The audio signal beeps when the foc button.

Slide the audio-signal switch to to set the signal on.

To set the signal off, slide the audio-signal switch to OFF.



Changing the plug-in filters

A normal filter is equipped with your lens.

- The filter is a part of optical system component. Be sure to attach either the normal filter or the polarizing (circular) filter when taking pictures.

To change the plug-in filter

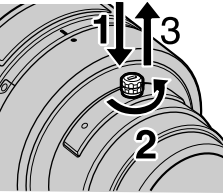
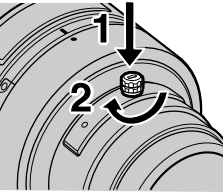
- Push down the filter-holder lock and turn it counterclockwise 90° towards the lens front until the orange index is aligned with the filter holder, and then lift the filter holder up.
- Align the filter-holder lock orange index with the filter holder, face the side with the filter to the camera body, and then insert the filter holder into the lens barrel.
- Push down the filter-holder lock and turn it 90° to lock.
 - The filter-holder lock orange index is perpendicular to the holder.

To use the plug-in polarizing (circular) filter

- Adjust the focus while looking through the viewfinder.
- Rotate the adjust ring on the plug-in polarizing (circular) filter holder to adjust degree of polarization for shooting.
 - The polarizing (circular) filter can reduce or eliminate unwanted reflections (polarized light) from nonmetallic surfaces of water, glass, windows, shiny plastics, ceramics, paper, etc. It can also filter out polarized light from the atmosphere in general to produce richer colors. You can adjust the polarizing degree to get good contrast when taking photos of blue sky.
 - Generally, reflected light (polarization) should be minimized in photography, however you can adjust the polarizing degree for the desired effect.
 - The amount of light reaching the image sensor decreases. If your camera is set to manual exposure mode and you are using a hand-held exposure meter, or if your camera is set to manual exposure mode and you are using the Manual Flash Control function available on some external flash units, adjust the exposure compensation by opening the aperture 1 or 2 stops to the + side.

Specifications

Name (Model name)	Equivalent 35mm-format focal length*1 (mm)	Lens groups-elements*2	Angle of view 1*3	Angle of view 2*3	Minimum focus*4 (m (feet))	Maximum magnification (x)	Minimum f-stop	Filter diameter (mm)	Dimensions (maximum diameter × height) (mm (in.))	Mass (g (oz.)) (excluding tripod-mounting collar)
300mm F2.8 G (SAL300F28G)	450	12-13	8°10'	5°20'	2.0 (8.2)	0.18	f/32	42 (exclusive use)	Approx. 122×242.5 (5 1/16×9 3/8)	Approx. 2,310 (81 1/2)

*1 The value for equivalent 35mm-format focal length is based on Digital Single Lens Reflex Cameras equipped with an APS-C sized image sensor.

*2 The values of lens groups and elements include the protective element and plug-in filter.

*3 The value of angle of view 1 is based on 35mm-format cameras, and that of angle of view 2 is based on Digital Single Lens Reflex Cameras equipped with an APS-C sized image sensor.

*4 Minimum focus is the shortest distance from the image sensor to the subject.

- This lens is equipped with a distance encoder. The distance encoder allows more accurate measurement (ADI) by using a flash for ADI.
- Depending on the lens mechanism, the focal length may change with any change of the shooting distance. The focal length assumes the lens is focused at infinity.

Included items: Lens (1), Front lens cap (1), Rear lens cap (1), Lens hood (1), Strap (1), Normal filter (1), Plug-in polarizing (circular) filter (1), Trunk (1), Set of printed documentation

Designs and specifications are subject to change without notice.

α is a trademark of Sony Corporation.

Depth-of-field table (in meters)

	f/2.8	f/4	f/5.6	f/8	f/11	f/16	f/22	f/32
∞	921- ∞	651- ∞	460- ∞	326- ∞	230- ∞	163- ∞	115- ∞	81.6- ∞
30m	29.1-31.0	28.7-31.4	28.2-32.0	27.6-33.0	26.7-34.3	25.5-36.5	24.0-40.1	22.2-46.5
15m	14.8-15.2	14.7-15.3	14.6-15.5	14.4-15.7	14.2-16.0	13.8-16.4	13.4-17.1	12.8-18.1
10m	9.90-10.1	9.87-10.1	9.81-10.2	9.74-10.3	9.63-10.4	9.49-10.6	9.29-10.8	9.02-11.2
7m	6.95-7.05	6.94-7.06	6.91-7.09	6.88-7.13	6.83-7.18	6.76-7.26	6.66-7.38	6.53-7.54
5m	4.98-5.02	4.97-5.03	4.96-5.04	4.94-5.06	4.92-5.09	4.88-5.12	4.84-5.17	4.77-5.25
4m	3.99-4.02	3.98-4.02	3.98-4.03	3.97-4.04	3.95-4.05	3.93-4.07	3.90-4.10	3.86-4.15
3m	2.99-3.01	2.99-3.01	2.99-3.01	2.98-3.02	2.98-3.03	2.97-3.04	2.95-3.05	2.93-3.07
2.5m	2.50-2.51	2.49-2.51	2.49-2.51	2.49-2.51	2.49-2.52	2.48-2.52	2.47-2.53	2.46-2.55
2m	1.997-2.003	1.997-2.003	1.996-2.004	1.99-2.01	1.99-2.01	1.99-2.01	1.98-2.02	1.98-2.02