

Sony videoconferencing

Good business is good communication. And it's so much easier to communicate when you can see someone's face. It's now easy to make crisp, clear video calls over the Internet and it's as straight forward as making a phone call. With the partnership of Sony and Cisco Systems, two of the most popular videoconferencing units from Sony now integrate seamlessly with Cisco CallManager. It means they're simple to set up, easier to use and have many more features.

Because the Sony units integrate with your Cisco IP communication environment, you can manage videoconferencing and IP-telephony centrally. They have soft keys for commands like **call forwarding**, **transferring**, and **holding**. And you can access or set up a **corporate phone book** to call people in your organisation at the touch of a button.



The components:

Sony PCS-TL30P

Network ready out of the box the PCS-TL30P is an all-in-one videoconferencing systems and PC screen which includes a digital PTZ camera, a 17.1-inch widescreen XGA LCD display with integrated speakers and microphone in a single lightweight and slim body. This ideal for use on individual desktops and small meeting spaces as required.



Sony PCS-1P

Our most popular videoconferencing set-top unit, and the first in the industry to have high quality MPEG4 sound and video. It's ideal for meeting rooms of anything up to boardroom size. And because it'll integrate neatly into your existing Cisco network, it's easy to plan a meeting with large groups of people.



Sony PCS-TL50P

This sleek and sophisticated desktop unit has a 20-inch LCD screen, camera, microphone and speaker all built in. It works as a PC monitor and videoconferencing unit in one. So it can replace your PC screen, making it perfect for individual offices and where space is at a premium. It's user friendly and has excellent sound and picture quality.



PCS-G50P

Representing the best price/performance ratio currently available on the market, the stylish PCS-G50P combines advanced features with user-friendly operation and sets a new benchmark for mid-range voice, video and data communications. The PCS-G50P delivers television quality pictures and crystal-clear wideband audio in point-to-point or multipoint calls.



Cisco CallManager 4.x and 5.x

Call management software that makes video calls just as easy as making a phone call. By bringing video, voice and data together in the PCS-TL50P, PCS-TL30P, PCS-1P and PCS-G50P, Cisco CallManager is more flexible and reduces your costs.

Sample system configuration:

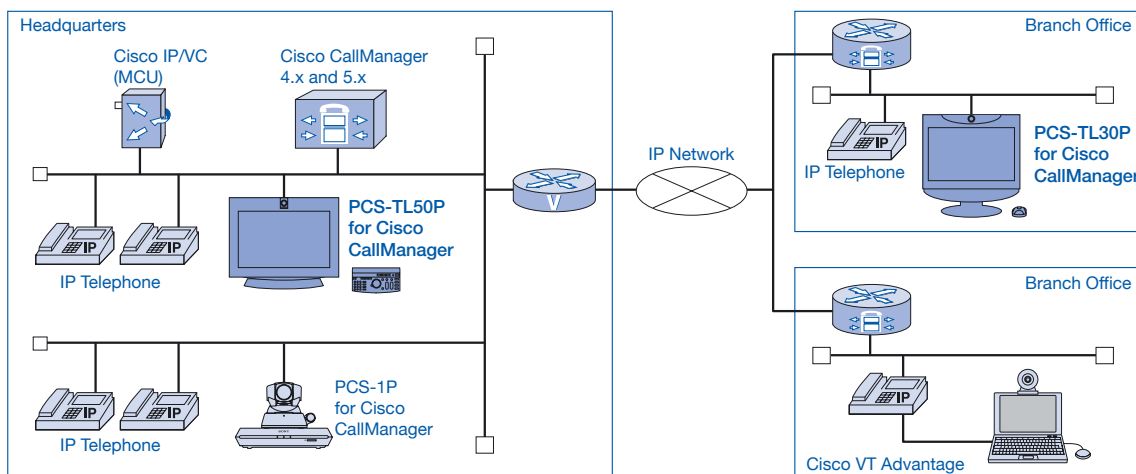

The benefits for users

Easy to use – Sony products with Cisco CallManager make videoconferencing as straightforward as making a phone call. Holding, transferring and forwarding calls, and conference features are all easy to use with the remote. And you don't need any networking experience to get started.

Connect any device, voice or video – It's easy to connect to several people even if some are not using a videoconferencing system. The PCS-TL50P, PCS-TL30P, PCS-1P and PCS-G50P let you talk directly to people on different devices, such as mobile phones and different networks, such as ISDN, IP or DSL.

The benefits for administrators

Central maintenance and management

Cisco's Skinny Call Control Protocol (SCCP) lets you to manage your network's phones and videoconferencing terminals from a central location. This means you can get a greater return on investment (ROI) from your existing communication infrastructure.

User support

The PCS-TL50P, PCS-TL30P, PCS-1P and PCS-G50P use a graphical user interface (GUI) that's familiar to users. So when you install new terminals minimal training is required. Also, administrators can remotely launch or manage calls and upgrade system software using SCCP.

Cisco is a registered trademark of Cisco Systems, Inc. and/or its affiliates in the U.S. and certain other countries.